



JK-8569A

Parts Manual

零件手册

 **杰克缝纫机**
JACK SEWING MACHINE
| [HTTP://WWW.CHINAJACK.COM](http://www.chinajack.com) |

From the library of: Superior Sewing Machine & Supply LLC

目录/CONTENTS

使用说明 (Use Manual)	1
套筒部件 (Bushing assemblies)	5
一、车壳部件 (Frame assemblies)	7
二、罩壳部件 (Cover assemblies)	9
三、缝台部件 (Cloth plate assemblies)	11
四、下轴部件 (Hook shaft assemblies)	13
五、上轴部件 (Main shaft assemblies)	15
六、针杆部件 (Needle bar assemblies)	17
七、护针部件 (Needle guard assemblies)	19
八、弯针部件 (Looper assemblies)	21
九、牙架部件 (Feed dog holder assemblies)	23
十、差动部件 (Differential assemblies)	25
十一、压脚部件 (Presser form assemblies)	27
十二、喂针部件 (Needle feeding assemblies)	29
十三、松线部件 (Thread loosening assemblies)	31
十四、过线部件 (Thread loosening assemblies)	33
十五、打线凸轮外移部件 (Outside cam assemblies)	35
十六、润滑部件 (Lubrication assemblies)	37
十七、油泵部件 (Oil pump assemblies)	39
十八、硅油盒装置部件 (Silicon oil device assemblies)	41
十九、线架部件 (Thread spool assemblies)	43
二十、油盘托板部件 (Oil plate assemblies)	45
二十一、DI部件专用件 (DI specific parts)	47
二十二、03、08专用部件 (03、08 specific parts)	49
二十三、01D专用部件 (01D specific parts)	51
二十四、02专用部件 (02 specific parts)	53
二十五、05专用部件 (05 specific parts)	55
二十六、02D、05专用部件 (02D、05 specific parts)	57
二十七、02D、05专用部件 (02D、05 specific parts)	59
二十八、05、07专用部件 (05、07 specific parts)	61
二十九、05、07专用部件 (05、07 specific parts)	63
三十、05、07专用部件 (05、07 specific parts)	65
三十一、21、22专用部件 (21、22 specific parts)	67
三十二、8569N专用部件 (8569N specific parts)	69
三十三、23专用部件 (23 specific parts)	71
三十四、附件部件 (Accessories assemblies)	73

⚠ 为了安全

对于缝纫机本身各种装置，我们充分考虑到它的安全性。请遵照基本的操作方法，安全的进行工作。

- 拆除为保证安全所设置的装置，零件的情况下使用，是非常危险的，请绝对不要拆除后使用。
- 缝纫机在使用时，请不要在缝纫机台板上放置工具及缝纫时不必要的物品。
- 在对缝纫机进行检修、调节、清扫、穿线、换针等工作时，为防止发生事故，请务必切断电源，在确认即使踩下缝纫机踏板，缝纫机也不转动之后，再进行操作。

⚠ OBSERVE THESE SAFETY PRECAUTIONS

Though Our takes the utmost care to produce safe sewing machines and devices, operators should follow these basic safety rules.

- To prevent accidents, do not remove safety devices or parts while operating the machine.
- Do not leave tools or other unnecessary objects on the machine table while operating the machine.
- Before maintenance, adjusting, cleaning, threading or replacing the needle, and to prevent accidents, be sure the power is turned off. Check that the machine will not operate when the pedal is pressed.

注意

使用离合式马达的情况下，在关掉电源①后因惯性作用会继续旋转。这时如不注意踩动缝纫机踏板②时，缝纫机会突然动作，这是很危险的。请在关掉电源后，仍继续踩动踏板②，直至缝纫机完全停下来为止。

Note

In case a clutch type motor is used, it will keep on rotating by inertia after turning off power supply. ①If the machine pedal ②is stepped on inadvertently, it is dangerous because the machine will move unexpectedly. keep on stepping on the pedal ② until the machine comes to a stop after turning off power supply.

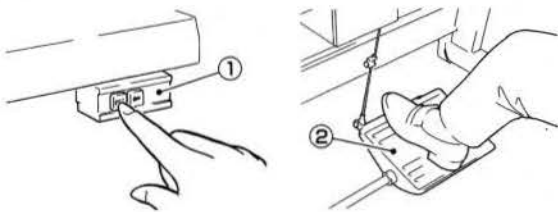

- 在离开缝纫机台时，请务必关掉电源。
- 停电时也请务必关掉电源。
- 为了总是安全地，运转良好的使用缝纫机，日常的点检是不可缺少的，请予以注意。
- Turn the power off before leaving the machine table.
- In the event of a power failure, be sure to turn the machine off.
- Check that the machine is securely grounded.

台板加工图

Schematic diagram to the machine table

请参照下图进行台板的加工

Cut the referring the diagram

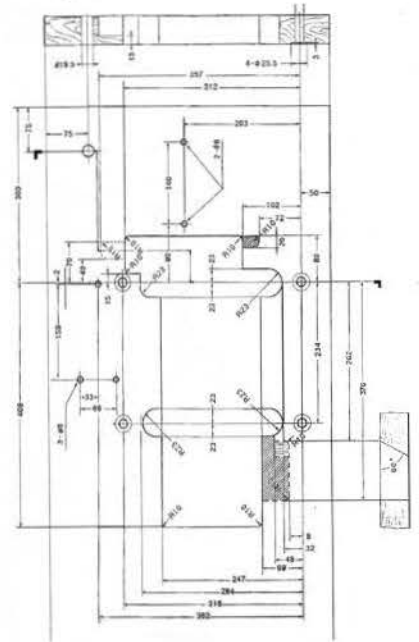

手动给油 Manual lubrication

手动给油是在缝纫机最初开始使用时，或相当一段时间重新开始时使用时，请供给2~3滴油。

机油请使用本公司指定的 (HIGH SPEED SEWING MACHINE OIL)(ISO粘度与VG22相同)。

Apply 2 or 3 drops of oil by hand when the machine is used for the first time or has been left unused for some time.

Note: Utilice [HIGH SPEED SEWING MACHINE OIL] recomendado por (ISO VG22)

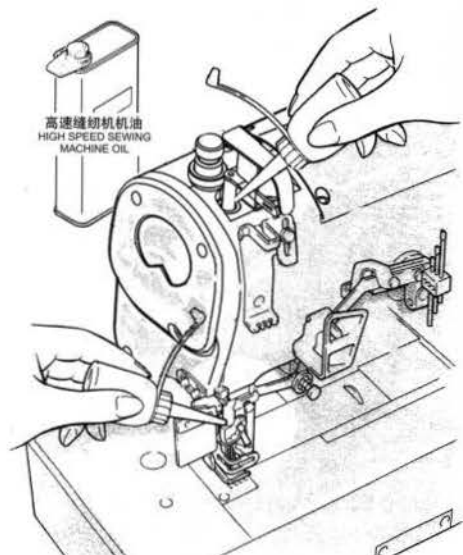

供油

加油量是使油面处于H线与L线之间为好。当油面低于L线时,就要及时补充机油。机油请使用杰克公司指定的[HIGH SPEED SEWING MACHINE OIL] (ISO粘度与VG22相同)。

Lubrication

After filling the oil pan, the oil surface should lie between (H) and (L) lines.

Add oil ,when the oil surface reaches or goes below(L).

Note:Use recommended [HIGH SPEED SEWING MACHINE OIL].(ISO VG22)

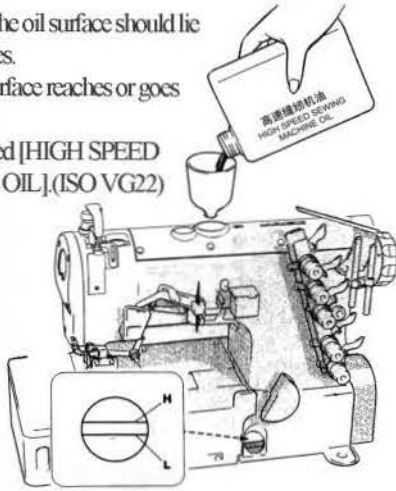

给HR装置供油

为了防止布纤维或线被切断,请尽早给HR装置供油。

注:硅油请使用本公司指定的冷却油。[请使用日本UNION CARBIDE(株)的UCCL-45(10)]

Filling the HR device with silicon oil

Fill the device with oil before it is too low in order to prevent needle thread breakage and fabric damage.

Note:Use recommended silicon oil [UNION CARBIDE CORPORATION] UCCL-45(10)

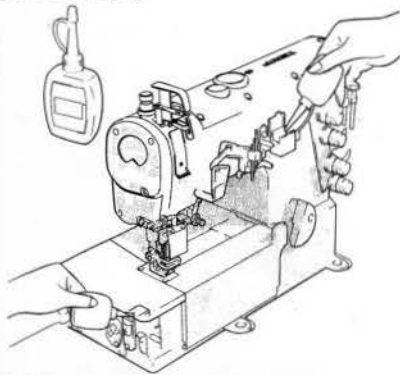

穿线的方法

- (1) 请掀起护眼板, 打开机盖 (3处)。
- (2) 抬起弯针挑线架。
- (3) 把机上原有的线与缝线用线绑结在一起。
- (4) 按下弯针挑线架, 弯针挑线架回到原位。
- (5) 针线 将针线拉到针眼前, 剪掉结头再次穿好针线。
- (6) 弯针线, 上装饰线直到拉出接头迁来后, 用剪刀剪齐接头, 整齐。

Threading

- (1) Open the eye guard and three covers.
- (2) Take up the bracket.

(3) Knot the preset thread and the thread being used together to thread the machine.

(4) Press down the bracket after threading. The looper thread take-up comes back.

(5) Needle Time the knots off nearly before passing through the eye of the needle to thread.

(6) Looper thread, Top cover thread Trim the knots off neatly after passing through the eye of the looper.

若机上原来没有线, 请参照穿线图正确进行穿线。

Be sure to thread the machine correctly by referring to the threading diagram.

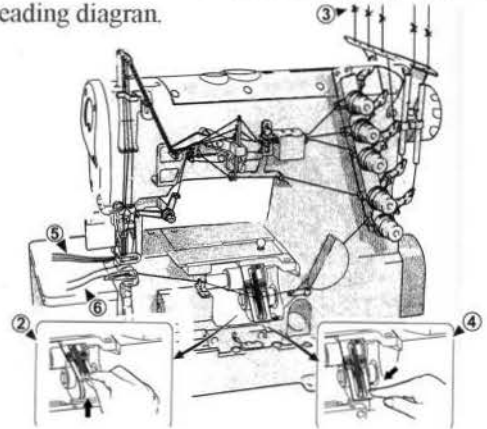

穿线图 (2针, 3针用) Threading diagram

- ① 若使用伸缩大的线时, 为点线A的方向。(通常为实线方向)
Broken lines(A) For more stretchable thread.
- ② 装饰线太松弛时用B, 用B仍松弛时用C, 装饰线太紧时用D
If the top cover thread is too loose, use broken line(B). If the top cover thread is still too loose after thread with broken line(B), use broken(C). If the top cover thread is too tight, use broken line(D).
- ③ 穿伸缩大的线时 穿伸缩小的线时
For more stretchable thread For less stretchable thread
- ④ 穿伸缩大的线时用点线E方向
Broken lines(E) For more stretchable thread
- ⑤ 若使用伸缩大的线时, 为点线F方向。(通常为实线方向)
Broken lines(F) For more stretchable thread.

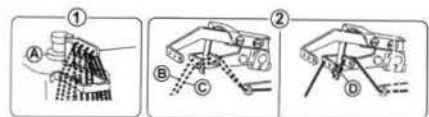

Solid lines for ordinary thread.

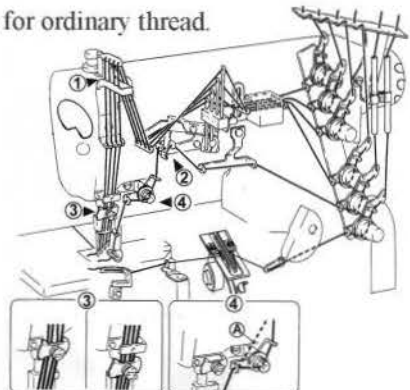

压脚压力调节

压脚压力的调节是松开螺帽①和旋转螺丝②来进行的。在能取得平稳针脚的范围內，尽量调得松一些为好。

Adjusting the presser foot pressure

Loosen adjusting (1) nut and turn adjusting screw (2) to adjust the presser foot pressure. It should be as light as possible, yet be sufficient to obtain the proper stitch formation.

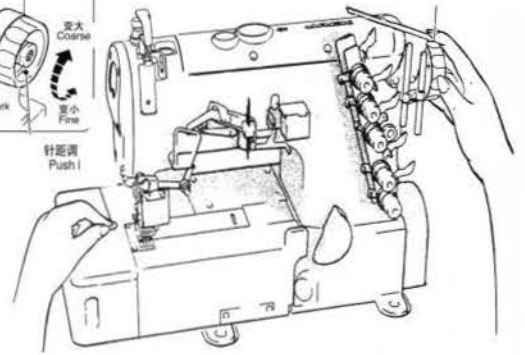
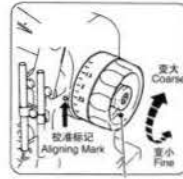
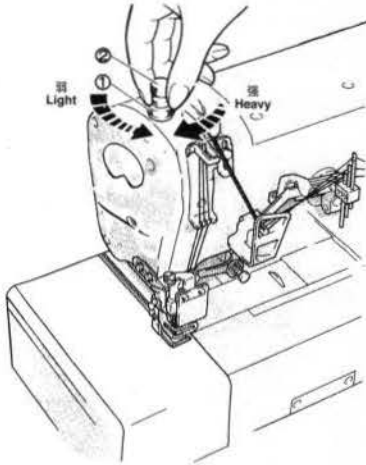

线状态的调节

线状态的调节是用针线状态螺帽①，上装饰线状态螺帽②，下针状态螺帽③来进行调节。

Thread tension

Make tension adjustments with the needle thread knob (1), top cover thread knob (2), and looper thread knob (3).



差动比的调节

差动比是通过松开螺帽①后，把调节杆②上下移动来进行调节的，调节后请拧紧螺帽①。

Adjusting the diff. feed ratio

Loosen nut (1) and move the lever up (2) and down to obtain the correct differential feed ratio, then tighten nut (1).

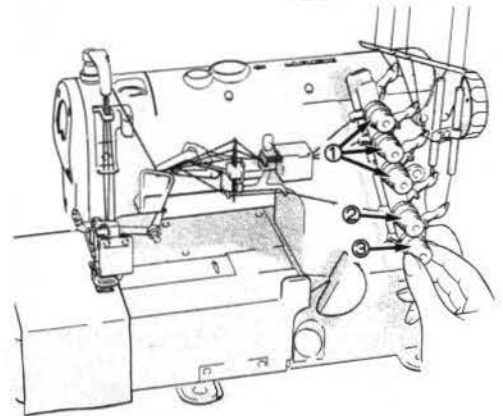
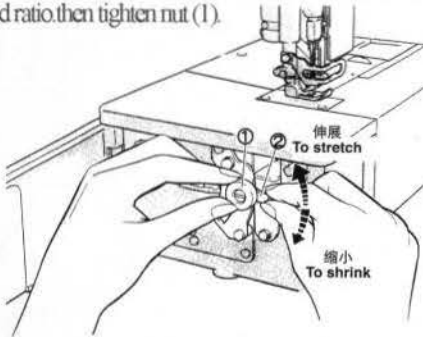

缝纫机的清扫

缝纫机的清扫，以针板槽及送布牙周围为主。

Cleaning the machine

Mainly the slots of the needle plate and the feed rows should be cleaned.

针脚长度的调节

摁住针距调节按钮，旋转手轮，针距调节按钮会陷进更深处。这时边摁住针距调节按钮，边转动手轮，使校准标记对准所希望的数值。针脚长度调节。注：针脚长度的调节务必请在调节差动比之后进行。

Adjusting the stitch length

While pressing the push button, turn the handwheel to seek the position at which the push button goes further into the depth. Then keeping the button pressed, turn the handwheel and set the desired scale to the aligning mark. Note: Stitch length adjustment must only be made after the differential feed ratio has been changed.

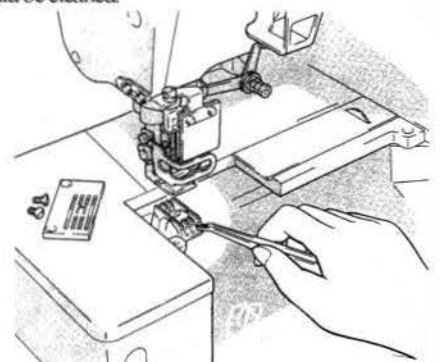

换针

1. 准确辨认针的前后，请将针凹向着后方，即背向操作者进行安装。
2. 针要牢固的插到孔的最深处。

Replacing the needle

1. Check the needle carefully to see that the scarf is turned to the rear of the machine.
2. Insert the needle to the proper depth, and fasten securely.

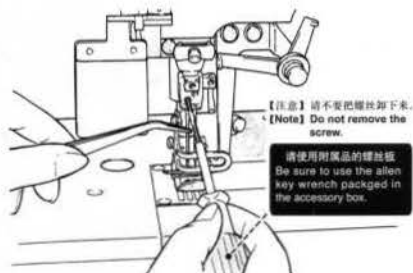
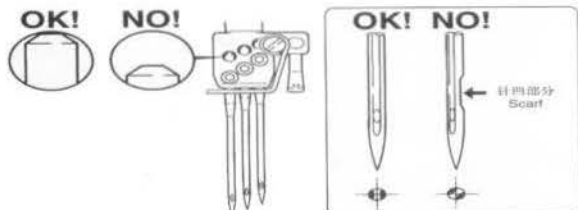

检查机油的循环

Cleaning the oil circulation

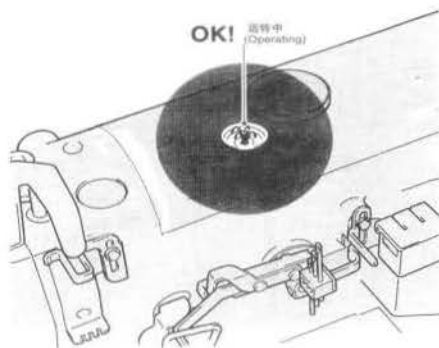

油过滤器的检点与更换

- 机油过滤器，请于每6个月来点检或更换一次。
- 检点和更换每隔6个月进行一次！

Cleaning and replace the oil filter

- Check and replace the oil filter every six months.
- Check and replace every 6 months !

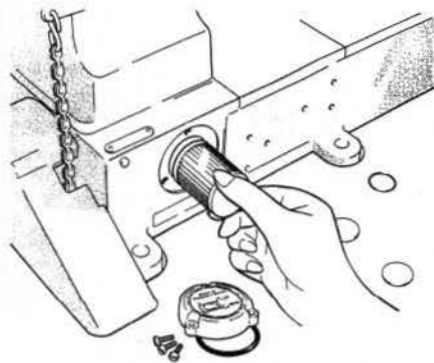

换机油

机油的更换，请在使用开始一个月后更换一次。然后，每6个月更换一次。

Replacing the oil

Replace the oil one month after the first use and every six months thereafter.

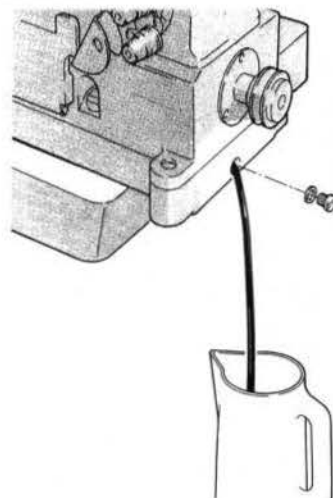

调整标准表 STANDARD ADJUST TABLE (mm)

机型	× □ □ □					
8569A(FA)-01GB	256	8.5	3.2*3.5	8.3*8.7	4.5*5	17
8569A-02BB						
8569A-03DB						
8569A-05CB						
8569A-07BB						
8569A-08AC	356	8.5	3.2*3.5	8.3*8.7	4.5*5	17
8569A-23BB						
8569A-23GB(L)	364	8.1	2.8*3.1	8.3*8.7	4.5*5	17
8569A-21BB	356	11.5	2.8*3.1	11.3*11.7	4.5*5	17
8569A-23BBL	256	11.5	2.8*3.1	11.3*11.7	4.5*5	17
8569A-23BB	356	8.1	2.8*3.1	8.3*8.7	4.5*5	17
8569A-23GBL	256	8.1	2.8*3.1	8.3*8.7	4.5*5	17

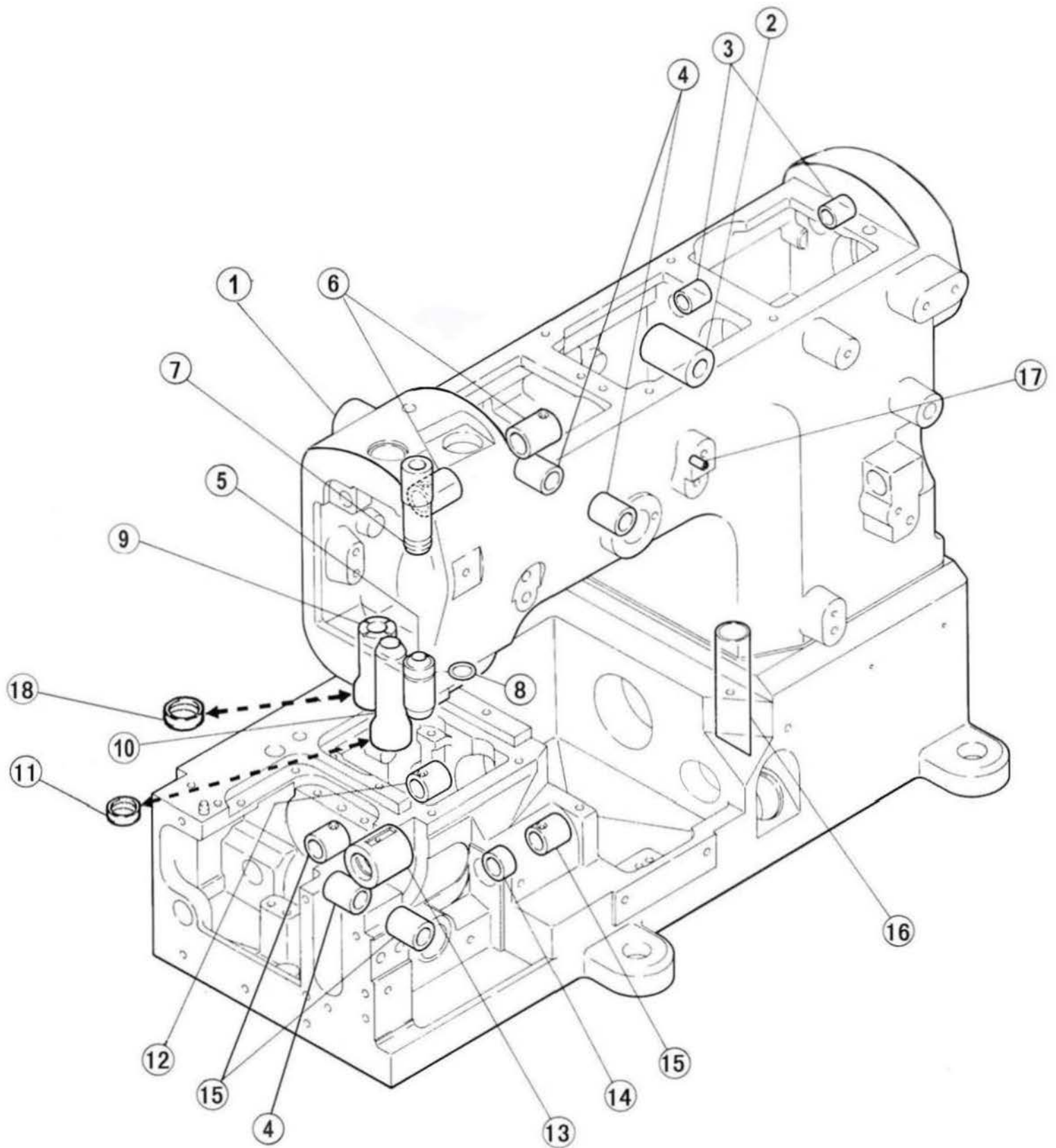

套筒部件(Bushing assemblies)

序号 Ref.No	公司件号 Part No	参考件号 Ref. Part. no	名称	Description	数量 Number
1	301780	250215-2	机壳	machine frame	1
2	30103036		压脚扳手轴套筒	bushing	1
3	30103037		抬压轴套筒	bushing	2
4	30103042	210297	过线座轴套筒	bushing	3
5	30103062		针杆下套筒	bushing	1
6	20103020	250141	摆动连杆轴套筒	bushing	2
7	30103017		针杆上套筒	bushing	1
8	001039		O型圈	O ring	1
9	30103038		喂针摆动轴套筒	bushing	1
10	30103035		压脚轴套筒	bushing	1
11	30122039		油封	plug	1
12	30103021	250135	弯针轴前套筒	bushing	1
13	30103010		主轴套筒	bushing	1
14	30103019		护针轴前套筒	bushing	1
15	20103014		前弯针轴后套筒	bushing	3
16	30221016	255020	铜油管	pipe	1
17	P03005		销 4×8	pin	1
18	20622019	210586	油封	plug	1

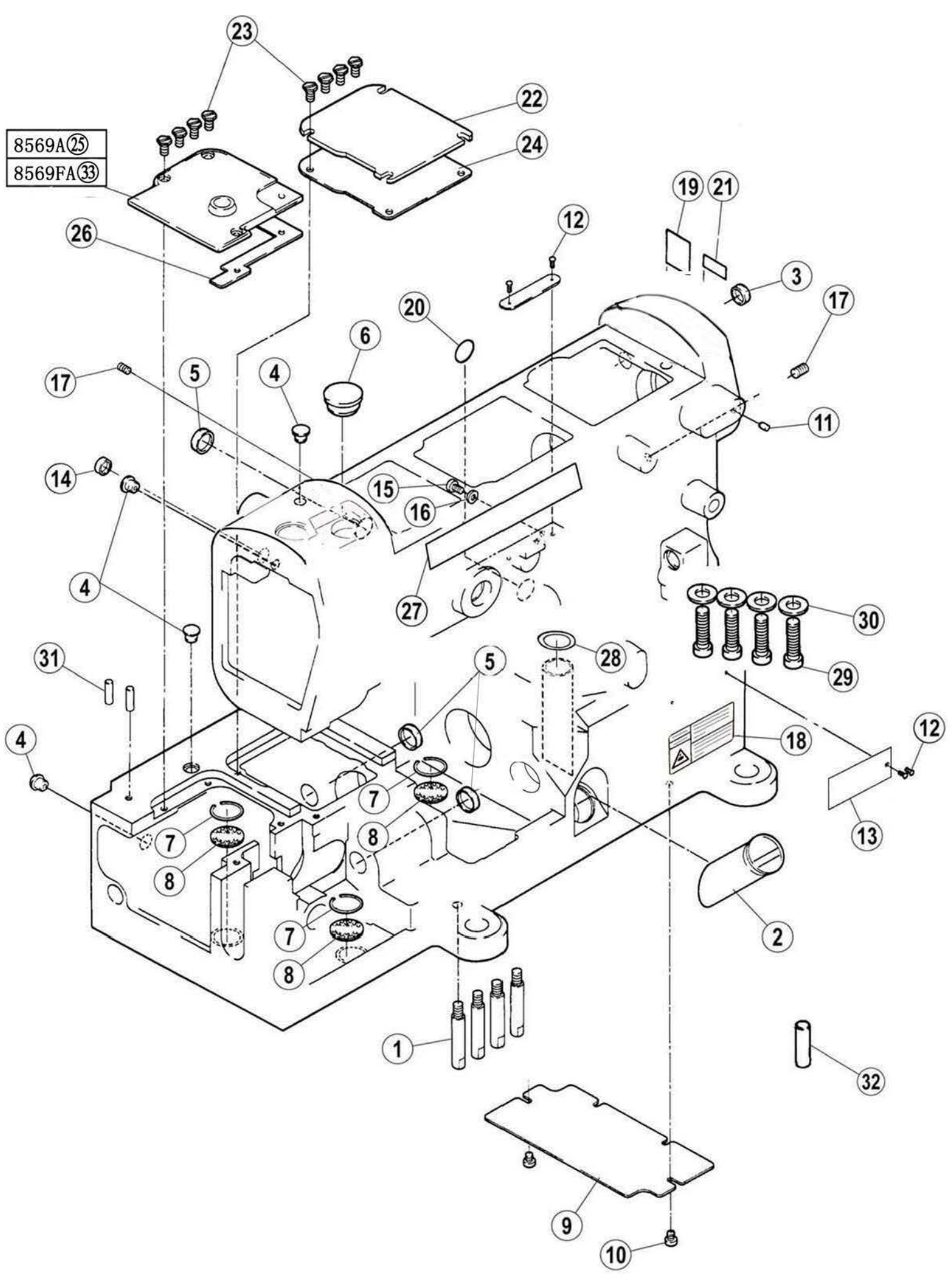

一、车壳部件(Frame assemblies)

序号 Ref.No	公司件号 Part No	参考件号 Ref. Part. no	名称	Description	数量 Number
1	301S30001	250117	机壳螺钉	shoulder pin	4
2	30111001	206590	油标	oil level gauge	1
3	30122004	240228	油封	plug	1
4	30122006	240052	油堵	plug	4
5	30122008	208173	油封	plug	3
6	30122005	240110	油封	plug	1
7	H01001	240001	挡圈 18	ring	3
8	30112001	255002	滤油网	filter	3
9	30112002	250049	盖板	cover	1
10	S01002	7017	螺钉 M4×6.5	screw	2
11	30122010	240127	油堵	mark	1
12	R03001	210679	铆钉 2.5×4	pin	2
13	30137001	250233	机型牌	sticker	1
14	30122007	205088	油封	plug	1
15	S01004	7019	螺钉 M4×7.8	screw	1
16	W01001	303448	垫圈 4	washer	1
17	S12004	4556	螺钉 M6×10	screw	2
18	20131063		警示牌	sticker	1
19	30137003		标牌	sticker	1
20	30122036		密封圈	sticker	1
21	30137004		警示牌	sticker	1
22	30101005	250003	下节右盖	top cover (right)	1
23	L02001	7084	螺栓 M4×8	screw	8
24	30122003	250004	下节右盖垫	gasket	1
25	30101004	250069	下节左盖	top cover plate (left)	1
26	30122002	250020	下节左盖垫	gasket	1
27	30131003	250215-2	商标牌	name plate	1
28	001001		O型圈 15×2.65	o ring	1
29	S05001		螺钉 M10×27.5	screw	4
30	W02003		垫圈 10	washer	4
31	P01001		销	pin	2
32	P02001		销	pin	1
33	30101068		下节左盖	top cover plate (left)	1

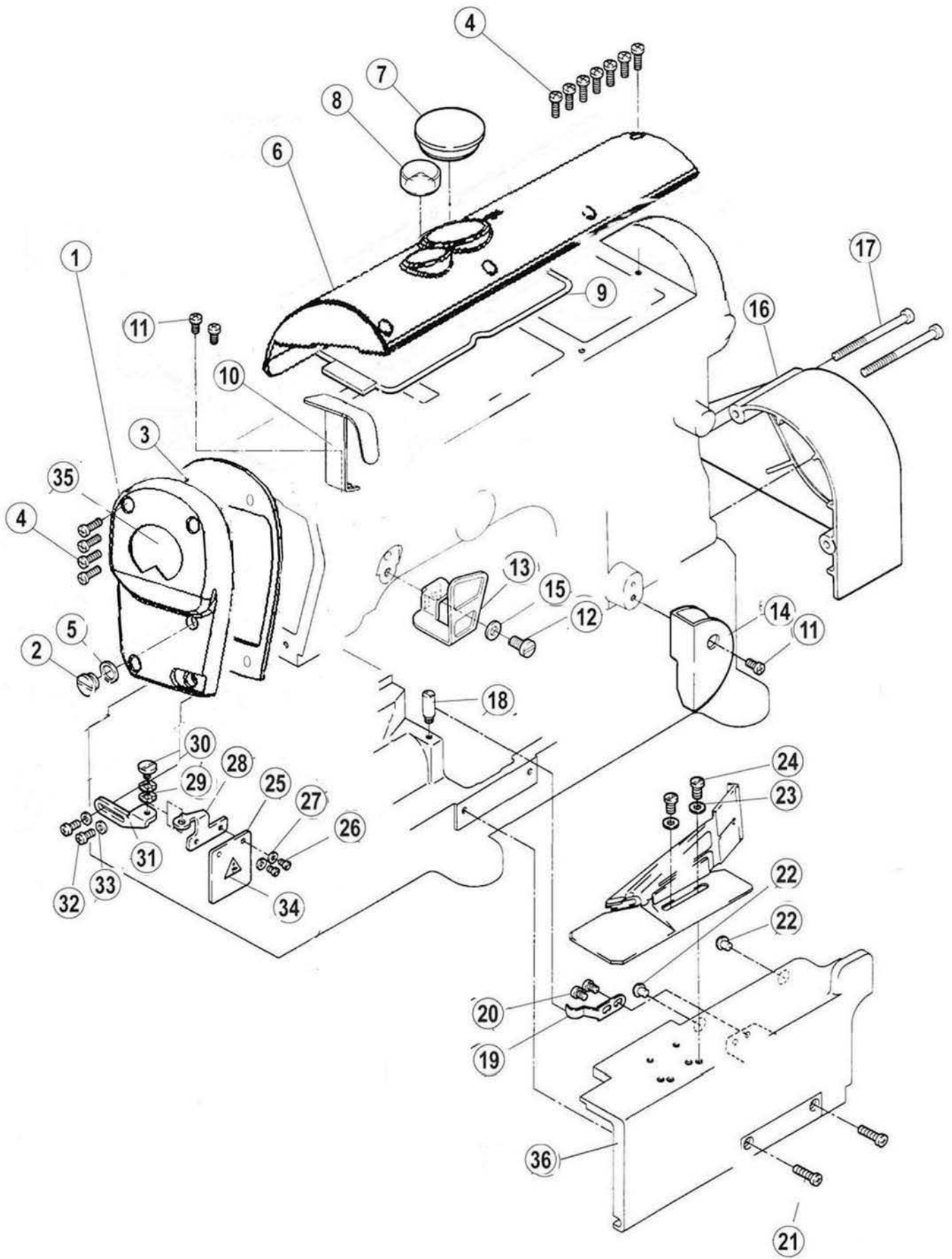

二、罩壳部件(Cover assemblies)

序号 Ref.No	公司件号 Part No	参考件号 Ref. Part. no	名称	Description	数量 Number
1	301435	250016-AUD	机头左盖(喷漆)	arm cover (left)	1
2	301S11001	5242	机头左盖螺钉	screw	1
3	30122036	250017	机头左盖垫	washer	1
4	S04019	7021	螺钉 M4×12	screw	11
5	30128001	240263	垫圈	washer	1
6	301433	250149	上盖(喷漆)	arm cover (top)	1
7	30122012	240226	密封盖	plug	1
8	30111022	179107-05	油标盖	oil sight window	1
9	30122013	250019	上盖垫	washer	1
10	30112102		针杆护罩	needle bar cover	1
11	S01004	7019	螺钉 M4×7.8	screw	3
12	301S11002		护罩螺钉	screw	1
13	30112006	250023	过线护罩	threan takeup cover	1
14	300135	250005	弯针护线板(喷漆)	looper thread guide cover	1
15	W01003	207924	垫圈 6	washer	1
16	30111004	250022	皮轮护罩	puller cover	1
17	301S11003	7075	带轮护罩螺钉	screw	2
18	301S30002	7089	左侧盖簧螺钉	screw	1
19	30127001	250051	前罩簧	flat spring	1
20	S01002	7017	螺钉 M4×6.5	screw	2
21	S01007	7023	螺钉 M4×13.5	screw	2
22	30122015	210025	前罩防振垫	cushion	2
23	W01004	204585	垫圈 5	washer	2
24	S01011	7024	螺钉 M5×10	screw	2
25	30111003	250257	有机玻璃罩	eye guard	1
26	S01006		螺钉 M3×4.5	screw	2
27	W01002	202875	垫圈 3	washer	2
28	30112005	250256	护罩架	bracket	1
29	W03001		垫圈 6	washer	2
30	301S20001	7066	护罩座固定螺钉	screw	1
31	30112004	250255	护罩座	bracket	1
32	S01004	7020	螺钉 M4×7.8	screw	2
33	W01001	303448	垫圈 4	washer	2
34	30137005		护罩警示牌	sticker	1
35	30337001		商标牌	sticker	1
36	300136	250011	前罩缝台(喷漆)	arm cover (top)	1

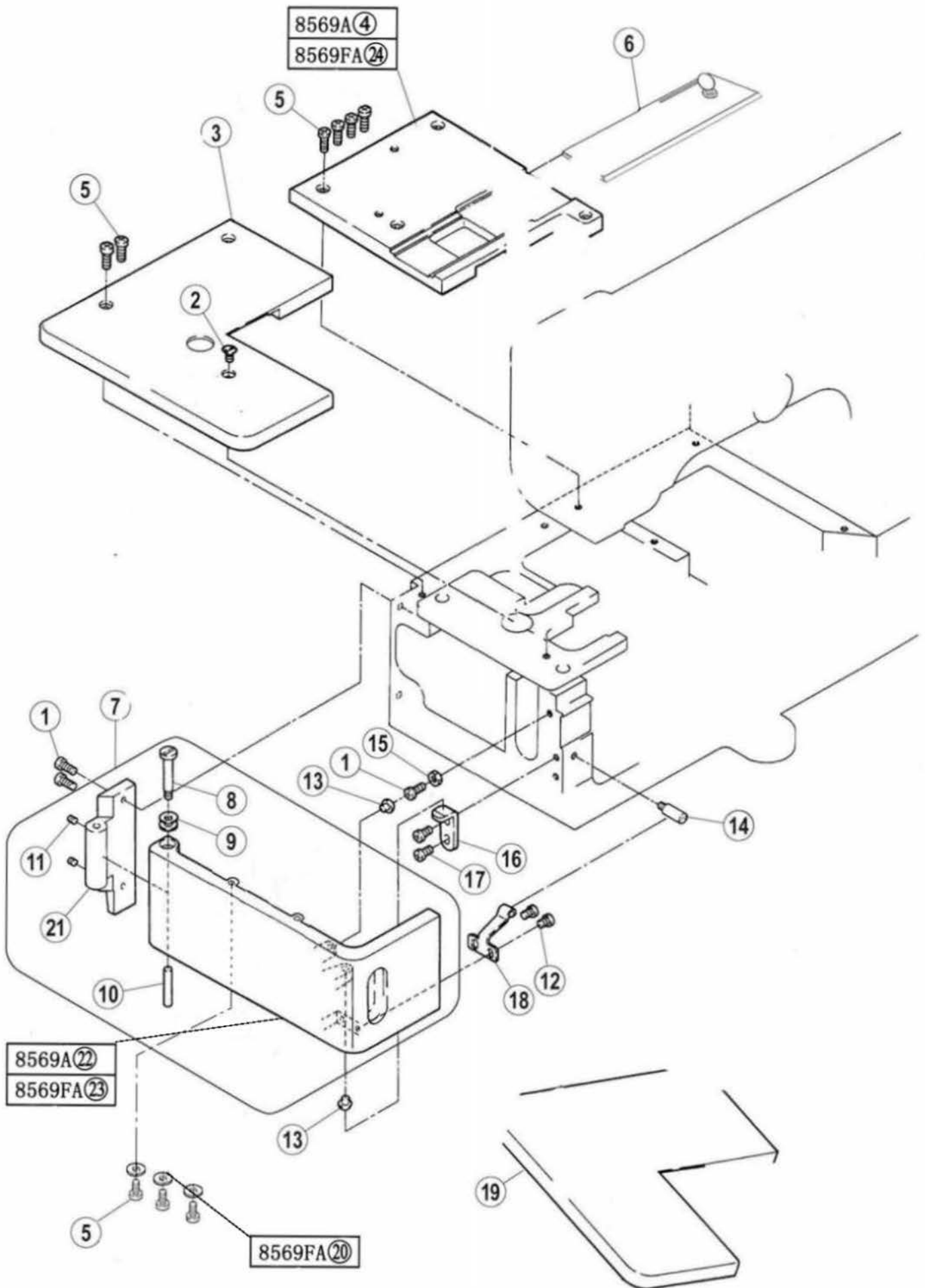

三、 缝台部件(Cloth plate assemblies)

序号 Ref.No	公司件号 Part No	参考件号 Ref. Part. no	名称	Description	数量 Number
1	S01005	7020	螺钉 M4×10	screw	3
2	S02001	7043	螺钉 M4×6	screw	1
3	300139	250052-BSD	左缝台盖 (喷漆)	bed cover(left)	1
4	300137	250074-ASD	右缝台盖 (喷漆)	bed cover(right)	1
5	S01003	7021	螺钉 M4×12	screw	9
6	30115001	250071-91	推板	cover	1
7	300138	250039-SD	侧盖组件 (喷漆)	side coverassy	1
8	301S20004	250037	侧盖合扇销钉	screw	1
9	30128002	201191	弹簧垫圈	spring	2
10	301S30006	250038	销螺钉	pin	1
11	S10001	4535	螺钉 M3×4	screw	2
12	S01002	7017	螺钉 M4×6.5	screw	2
13	30122015	210025	前罩防振垫	cushion	2
14	301S30002	7089	左侧盖簧螺钉	screw	1
15	N01001	4821	螺母 M4	nut	1
16	30112008	250047	挡块	bracket	1
17	S01004	7019	螺钉 M4×7.8	screw	2
18	30127002	206023	侧盖簧	flat spring	1
19	30112079		不锈钢缝台	bed cover	1
20	20528017		垫片	washer	3
21	300793		侧盖合扇	cover	1
22	3011101900		缝台裙组件	bed cover	1
23	3011101900		缝台裙组件	bed cover	1
24	300654		缝台盖(喷漆)	bed cover	1

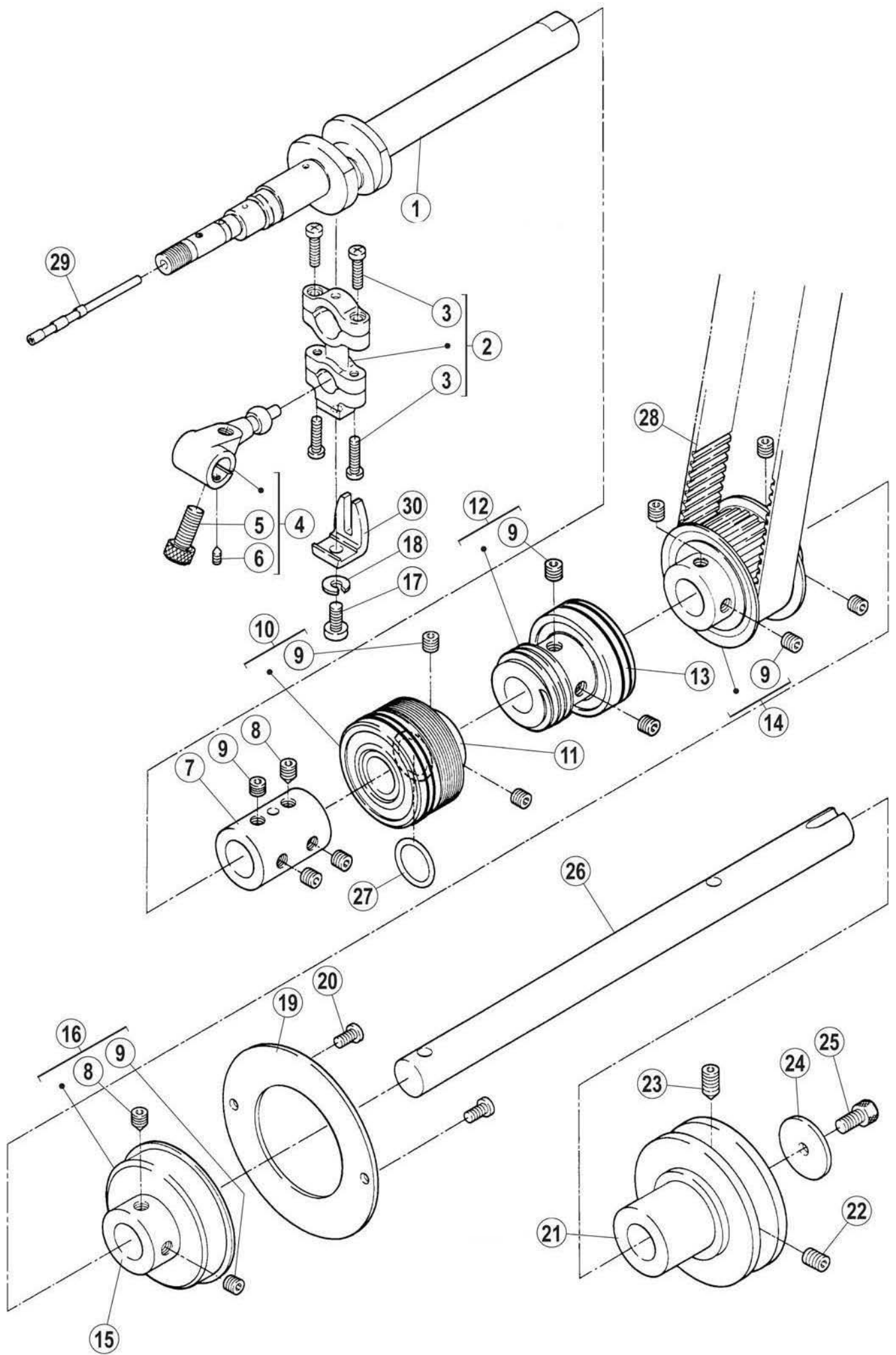

四、 下轴部件(Hook shaft assemblies)

序号 Ref.No	公司件号 Part No	参考件号 Ref. Part. no	名称	Description	数量 Number
1	400068	250501B-91	下轴	crankshaft assy	1
2	400060	2505009-92	连杆组件	connection assy	1
3	201S20015	7015	螺钉 M3.5×13	screw	4
4	30104002	252008	下轴曲柄	crank	1
5	S05002	4534	螺钉 M6×0.75×15	screw	1
6	S12002	4545	螺钉 M3×4	screw	1
7	30103004	250506	接轴套	joint	1
8	S12003	4555	螺钉 M6×7	screw	2
9	S10029	4547	螺钉 M6×0.75×5	screw	12
10	3012400300	250508-91	油封轴承	bearing	1
11	30103006	250508	中轴套	bushing	1
12	30103008	250543	蜗杆	bushing	1
13	3012400400		油封轴承	bearing	1
14	30125006	250511-1	下轴同步带轮	gear(lower)	1
15	30103009	250530	轴承套	bushing	1
16	B01003	250504-91	轴承 6304Z	bearing	1
17	301S11004	4019	比叉螺钉	screw	1
18	W02001	202286	垫圈 5	washer	1
19	30108001	250514	轴承挡圈	cover	1
20	S01004	7019	螺钉 M4×7.8	screw	2
21	30101015	250515	皮带轮	machine puller	1
22	S10009	4541	螺钉 M6×8	screw	1
23	S12001	4556	螺钉 M6×8	screw	1
24	30128005	240126	垫圈	washer	1
25	S05003	4501	螺钉 M5×10	screw	1
26	30102066	250507	下后轴	shaft	1
27	001001	206837	O型圈 15×2.65	o ring	1
28	30135002	206050C	同步带	timing belt	1
29	30126001	250525	调节销	adjusting bar	1
30	30109001	201074	比叉	guide	1

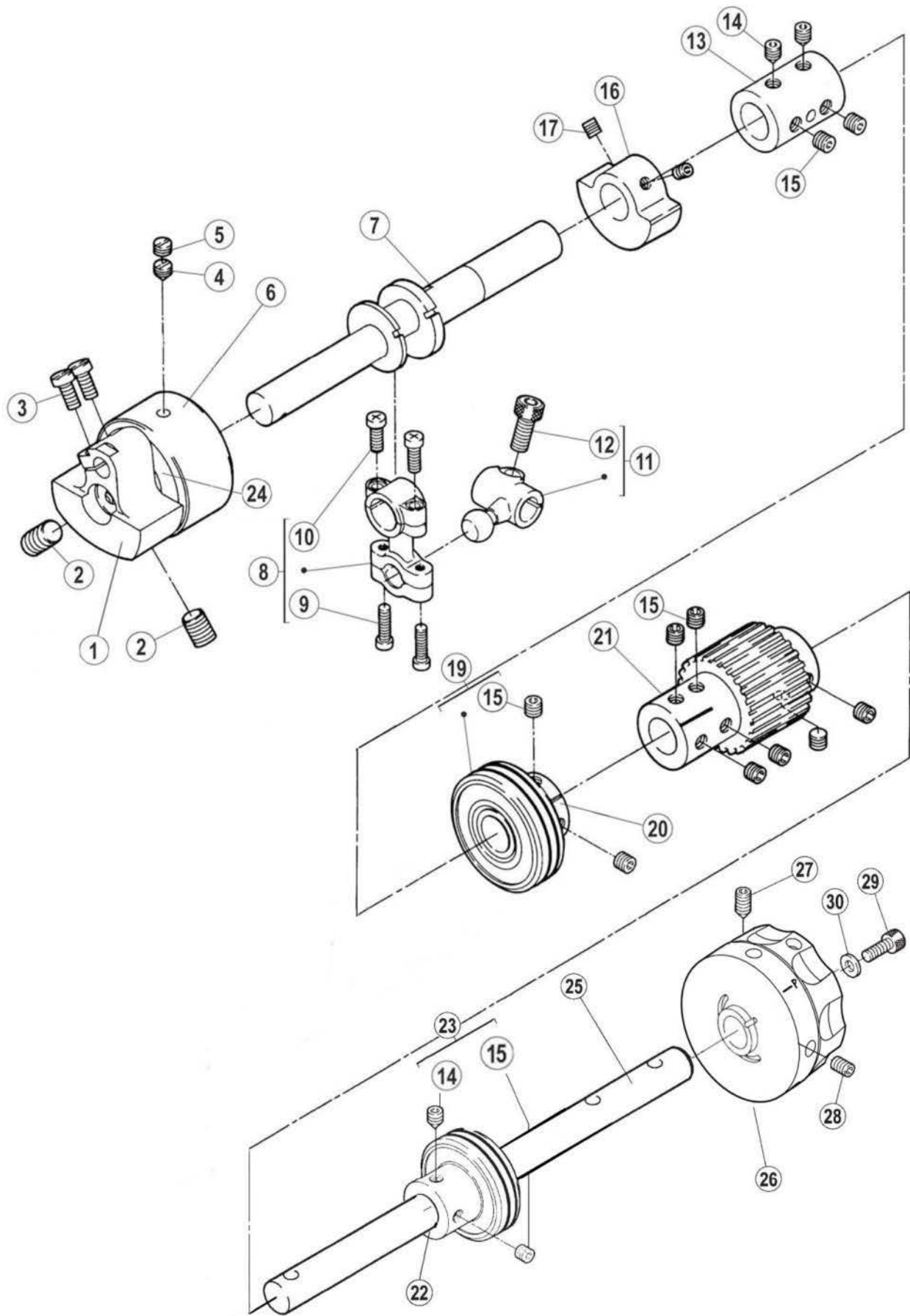

五、 上轴部件(Main shaft assemblies)

序号 Ref.No	公司件号 Part No	参考件号 Ref. Part. no	名称	Description	数量 Number
1	400307	250526B92	针杆曲柄	motion assy	1
2	S10004	4592	螺钉 M8×1×12	screw	2
3	S01011	7028	螺钉 M5×10	screw	2
4	S08001	7153	螺钉 M6×0.75×3.5	screw	1
5	S11001	7152	螺钉 M6×0.75×6	screw	1
6	30103015	250526	轴承套	bushing	1
7	400065	250517A	上轴	crankshaft	1
8	400061	253500-92	连杆组件	connection assy	1
9	S01003	7021	螺钉 M4×12	screw	2
10	S01008	7015	螺钉 M3.5×13	screw	2
11	30104006	253501A	弯针曲柄	crank assy	1
12	S05002	4534	螺钉 M6×0.75×15.2	screw	1
13	30103004	250506	接轴套	joint	1
14	S12003	4555	螺钉 M6×0.75×7	screw	3
15	S10029	4547	螺钉 M6×0.75×5	screw	11
16	30109003	250524	上轴平衡块	balance weight	1
17	S10002	4514	螺钉 M5×5	screw	2
19	3012400400	250529-91	油封轴承	bushing	1
20	30103012	250529	轴承套	bushing	1
21	30125002	250521	上轴同步带轮	gear (upper)	1
22	3012400400	250529-91	油封轴承	bearing	1
23	30103014	250528	轴承套	bushing	1
24	B01005		轴承 6203	bearing	2
25	30202004		后轴	shaft	1
26	301434	250523AUD	手轮 (刻好字)	handwheel	1
27	S12001	4556	螺钉 M6×8	screw	1
28	S10009	4541	螺钉 M6×8	screw	1
29	S05004	4501	螺钉 M5×14	screw	1
30	W01004	204585	垫圈 5	washer	1

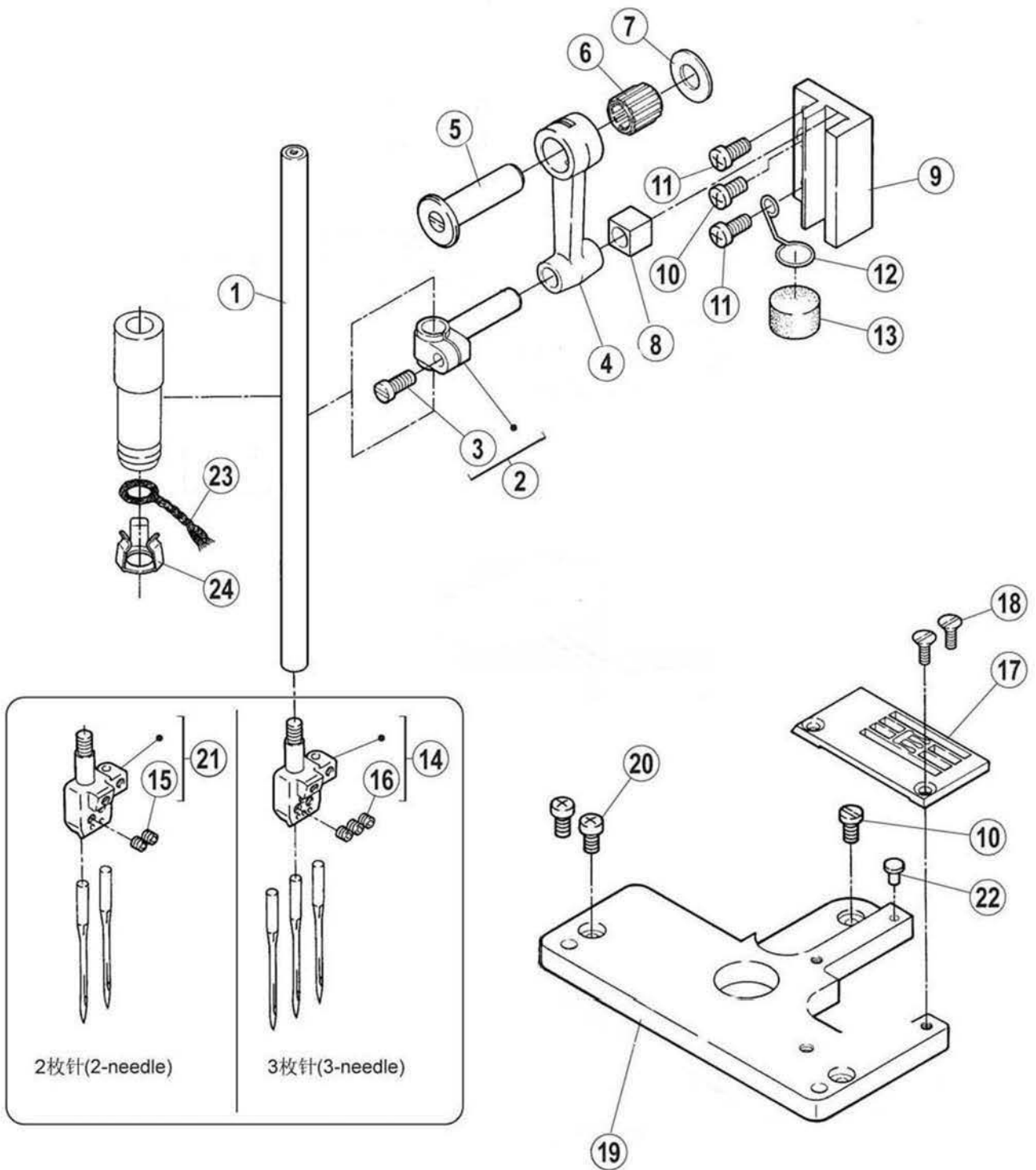

六、针杆部件(Needle bar assemblies)

序号 Ref.No	公司件号 Part No	参考件号 Ref. Part. no	名称	Description	数量 Number
1	30102008	251000-91	针杆	needle bar	1
2	30102009	206061	针杆轧头	needle bar pin	1
3	301S11005	5325	针杆轧头螺钉	screw	1
4	30105005	206052	针杆连杆	link/needle bar drive	1
5	30102010	206053	针杆连杆轴	pin	1
6	B07001	240098	轴承 8×12×12	needle bearing	1
7	30128006	240101	针杆连杆轴垫圈	washer	1
8	30109004	206063	针杆滑块	block	1
9	30109005	206062	滑块导座	guide block/needle bar	1
10	301S11024	7082	滑块导座螺钉	screw	2
11	S01003	7021	螺钉 M4×12	screw	2
12	30127003	251009	毛毡弹簧	spring	1
13	30123002	179040-05	毛毡	felt	1
14	30134001	257518-56	356针古	needle holder	1
15	S10026	4554	螺钉 M3×3	screw	2
16	S10026	4554	螺钉 M3×3	screw	3
17	30115002		356针板	needle plate	1
18	301S17001	5373-HC	针板螺钉	screw	2
19	30109006	251007	针板座	bracket	1
20	S01004	7019	螺钉 M4×7.8	screw	2
21	30134006		240针古	needle holder	1
	30134004		248针古	needle holder	1
22	30122018	240123	防振垫	cushion rubber	1
23	20523005	202176	油线	oil wick	1
24	30112009	206524	油线托	oil wick retainer	1

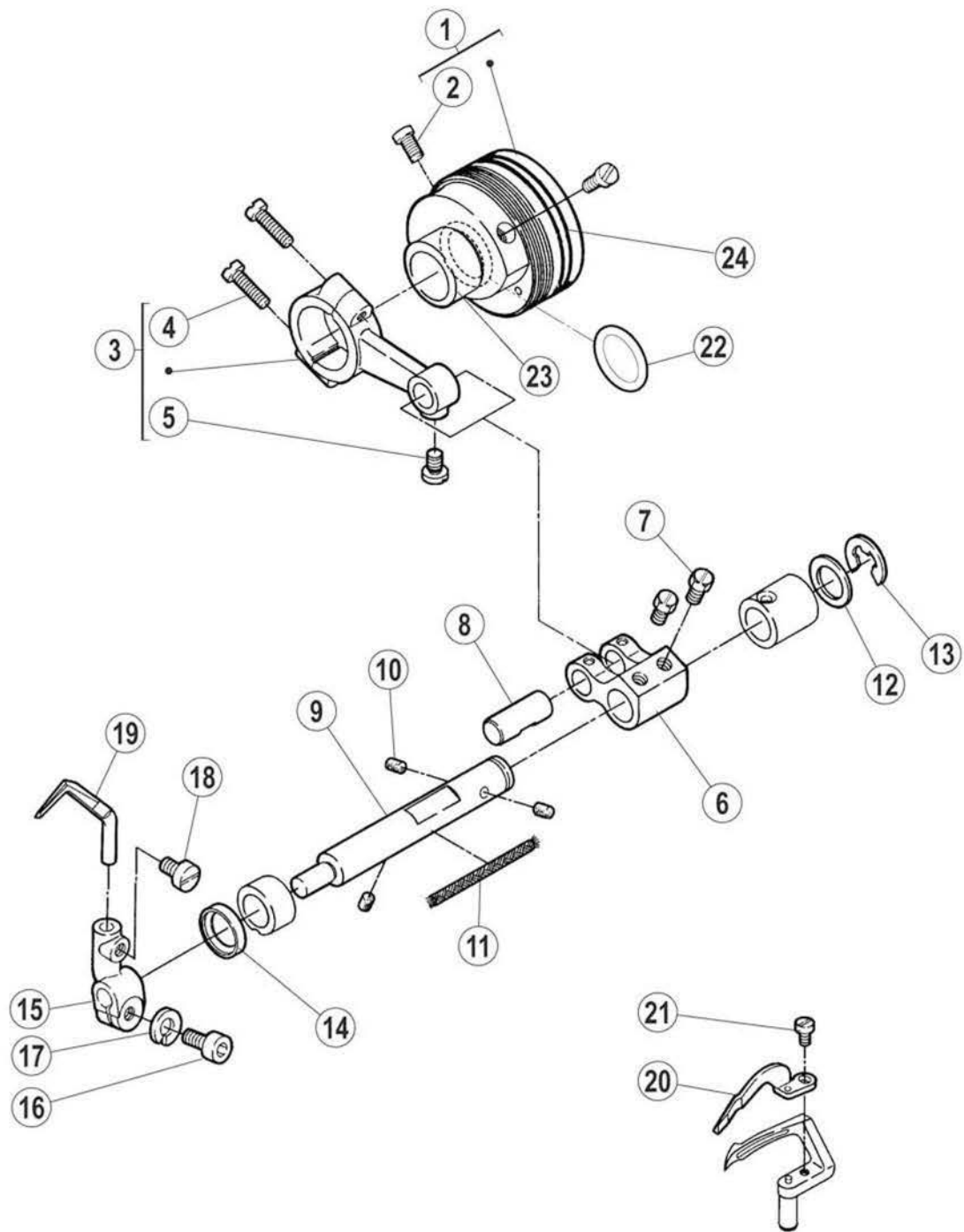

七、护针部件(Needle guard assemblies)

序号 Ref.No	公司件号 Part No	参考件号 Ref. Part. no	名称	Description	数量 Number
1	B01001		轴承 6004Z	bearing	1
2	S10028	4539	螺钉 M5×6	screw	2
3	400062	255501-92	连杆组件	connection assy	1
4	S01008	7015	螺钉 M3.5×13	screw	2
5	301S11024	7082	滑块导座螺钉	screw	1
6	30104007	306093	弯针曲柄	crank	1
7	301S12001	5084	曲柄螺钉	screw	2
8	30126003	205495	曲柄销	pin	1
9	30102011	251518	护针轴	shaft	1
10	30123001	206748	毛毡	felt	3
11	20523005	202176	油线	oil wick	1
12	30128008	240102	护针轴垫圈	washer	1
13	H05001	205061	挡圈 10	ring	1
14	30122019	204052A	油封	oil seal	1
15	30104009	251519	护针挡架	lever assy	1
16	S05003	4500	螺钉 M5×10	screw	1
17	W02001	303067	垫圈 5	washer	1
18	S01002	7017	螺钉 M4×6.5	screw	1
19	30117002	257551B	后护针挡	needle guard (rear)	1
20	30117003	257553	前护针挡	needle guard (front)	1
21	S01012	7031	螺钉 M2.5×4	screw	1
22	001001		O型圈 15×2.65	o ring	1
23	30110002	251517	偏心凸轮	eccentric	1
24	30122017		轴承槽油封	oil seal	2

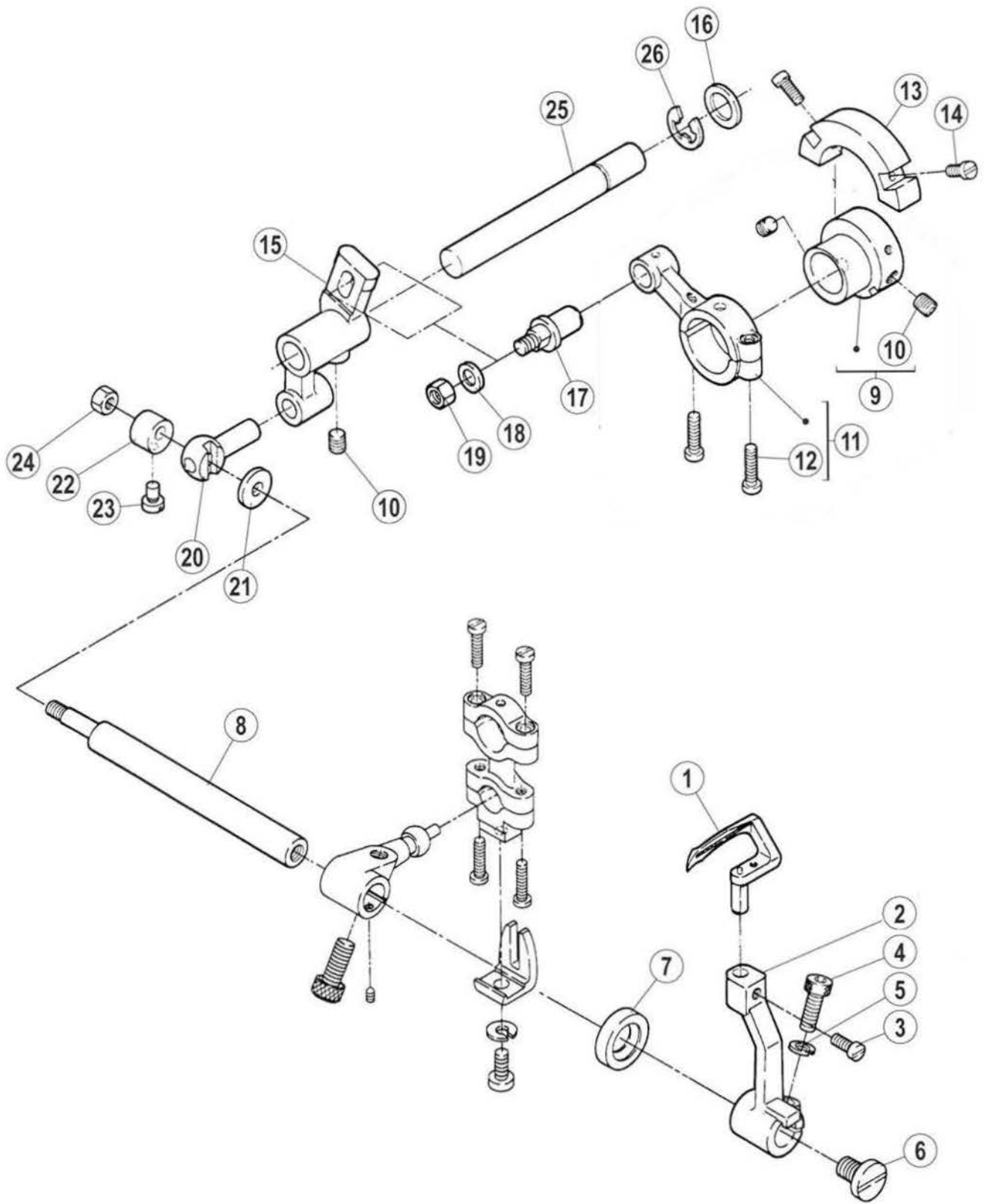

八、弯针部件(Looper assemblies)

序号 Ref.No	公司件号 Part No	参考件号 Ref. Part. no	名称	Description	数量 Number
1	3011700900	257550-91	弯针	looper	1
2	30104012	252007	弯针架	looper holder assy	1
3	S01004	7019	螺钉 M4×7.8	screw	1
4	S05004	4501	螺钉 M5×14	screw	1
5	W02001	303067	垫圈 5	spring washer	1
6	S01014	7085	螺钉 M6×0.75×9.6	screw	1
7	20622019		油封	oil seal	1
8	30102014	252006	弯针架轴	shaft	1
9	30110005	252000	摆架偏心轮	eccentric assy	1
10	S10006	4539	螺钉 M5×6	screw	3
11	400063	252001-92	连杆组件	connection assy	1
12	201S20015	7015	螺钉 M3.5×13	screw	2
13	30109007	252010	平衡块	balance weight	1
14	S01009	7011	螺钉 M3×7.5	screw	2
15	30104010	252002	弯针摆动架	crank	1
16	30128008	240102	摆架轴垫圈	washer	1
17	30102013	179399-05	连杆轴	pin	1
18	30128032	240062	垫圈	washer	1
19	N01004	4805	螺母 M5	nut	1
20	30102015	252003	摆轴轧头	block pin	1
21	30128010	208028	垫圈	washer	1
22	30108002	208029	偏心挡圈	collar	1
23	301S12001	5084	曲柄螺钉	screw	1
24	N01001	4802	螺母 M4	nut	2
25	30102012	252004	摆架轴	shaft	1
26	H05001	205061	挡圈 10	ring	1

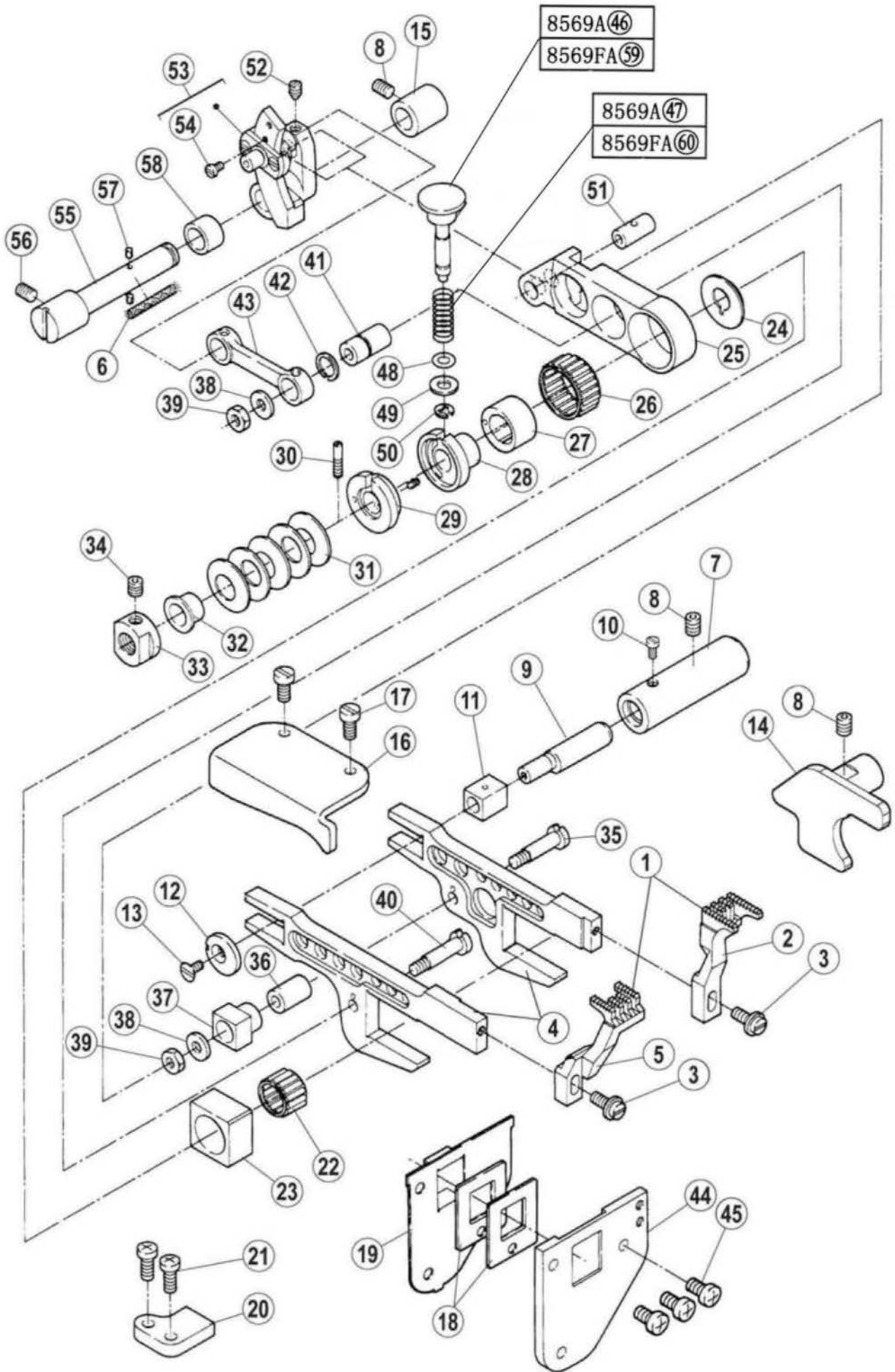

九、 牙架部件(Feed dog holder assemblies)

序号 Ref.No	公司件号 Part No	参考件号 Ref. Part. no	名称	Description	数量 Number
1	3011400700	257259-16F	差动送布牙组件	main feed dog assembly	1
2	30114001		356、364送布牙	main feed dog	1
3	301S30003	5590	差动送布牙螺钉	screw	2
4	400066	252500-91	差动送布牙架组件	main feed bar assembly	1
5	30114002		356、364差动牙	differential feed dog	1
6	20123021	202175	油线	oil wick	1
7	30103022	204129A	套筒	bushing	1
8	S10006	4539	螺钉 M5×6	screw	4
9	30102016	204128A	偏心轴	eccentric pin	1
10	301S12001	5084	曲柄螺钉	screw	1
11	30109008	205857	滑块	block/feed bar guide	1
12	30128011	204439A	偏心垫	washer	1
13	301S17002	5317	偏心轴螺钉	screw	1
14	30109009	252504	牙架挡板	guide(right)	1
15	30103031	206571	差动轴后套筒	bushing	1
16	30109010	252507	左挡板	guide(left)	1
17	L02003	7019	螺栓 M4×7	screw	2
18	30122020	206133	牙架油封	oilshield	2
19	30109011	252509	油封挡板	cover	1
20	30109012	252508	挡板	guide(lower)	1
21	S01005	7020	螺钉 M4×10	screw	2
22	B07002	206128	轴承 12×15×10	needle bearing	1
23	30109013	252519	抬牙滑块	block	1
24	30108003	252520	轴承挡圈	washer	1
25	30104013	206562	差动送布架	link/main feed	1
26	B07003	206125	轴承 17×21×10	needle bearing	1
27	30103023	252521	偏心轴承套	eccentric	1
28	30103024	252522	送布调节器	regulator	1
29	3010306500	252523-91	调节器套	eccentric retainer	1
30	301S30004	252516	调节器螺钉	screw	1
31	30128012	240125	碟形垫圈	spring	5
32	30103026	252525	垫圈套	spacer	1
33	301S16001	252543	调节螺母	nut	1
34	S10002	4514	螺钉 M5×5	screw	1
35	301S30005	206120	牙架螺钉	screw	1
36	30103027	206119	差动牙架套	bushing	1
37	30109014	206563	送布滑块	guide block	1
38	30128013	200098	垫片	washer	2
39	301S16002	3044	六角螺母	nut	2
40	301S30006	206123	差动牙架螺钉	screw	1
41	30103028	206566	差动连杆套	bushing	1
42	30129001	206565	开口挡圈	ring	1
43	30105010	206564	差动送布连杆	link/differential feed	1
44	30109015	251520	牙架挡板	bracket	1
45	S01004	7019	螺钉 M4×7.8	screw	3
46	30102017	252526	针距调节按钮	pin	1
47	30127004	240122	针距调节簧	spring	1
48	001004	206366	O型圈 4×1.8	o ring	1
49	30128032	204585	垫圈	washer	1
50	H05002	200555	挡圈 5	ring	1
51	30103029	206569	差动送布架套	pin	1
52	S12005	4546	螺钉 M4×4	screw	1
53	3010401500	252527-91	差动调整架组件	crank	1
54	S01012	7031	螺钉 M2.5×4	screw	1
55	30102018	252510	差动轴	shaft	1
56	S10002	4514	螺钉 M5×5	screw	1
57	30123002	207358	毛毡	felt	2
58	30103030	240119	差动轴前套筒	spacer	1
59	30126016		针距调节按钮	pin	1
60	30127026		针距调节簧	spring	1

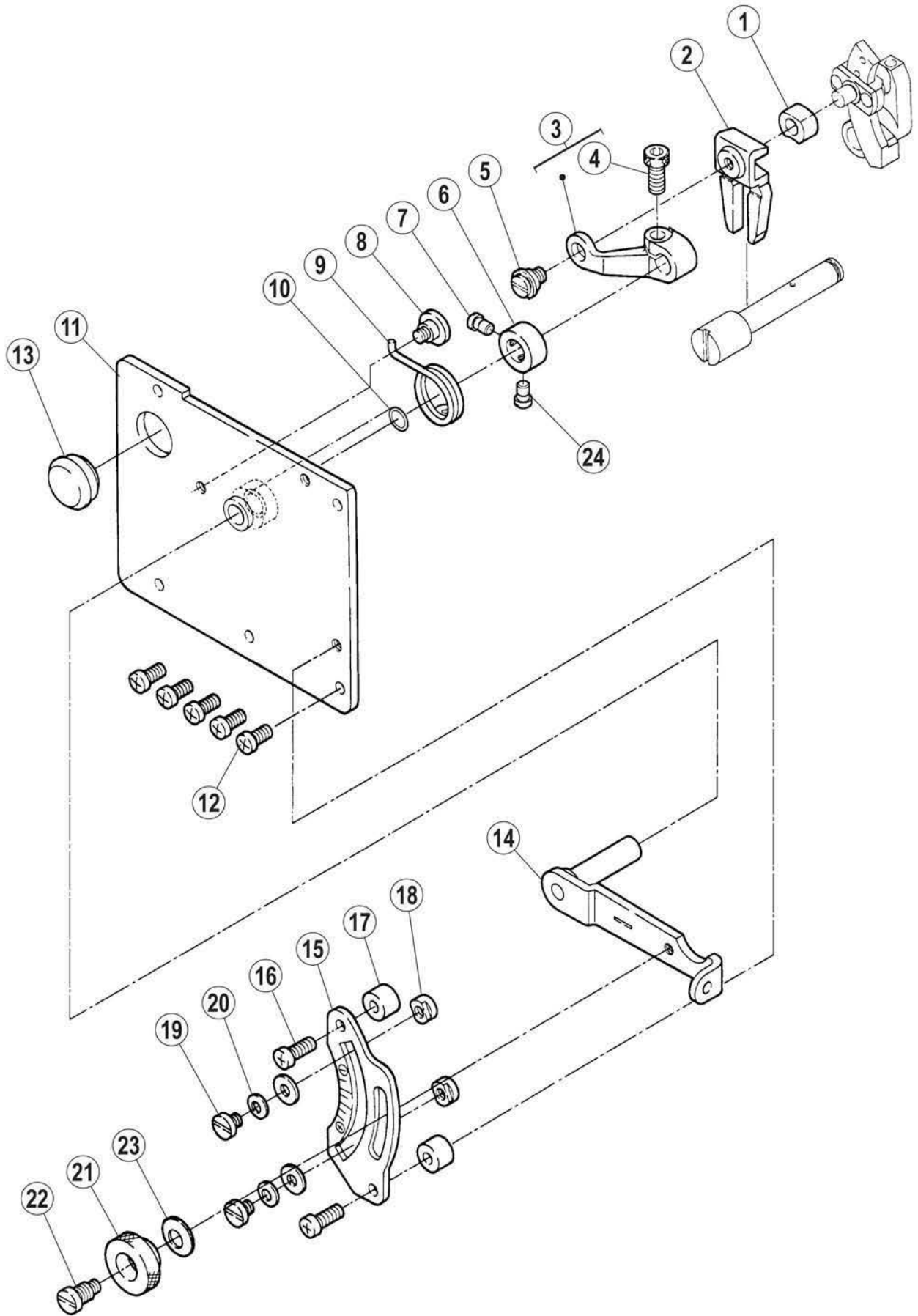

十、 差动部件(Differential assemblies)

序号 Ref.No	公司件号 Part No	参考件号 Ref. Part. no	名称	Description	数量 Number
1	30103032	252531	方套	block	1
2	30109016	252532	比叉	guide/block	1
3	30105012	252533	连杆	lever	1
4	S05005	4531	螺钉 M5×12	screw	1
5	301S20006	5316	连杆连接螺钉	screw	1
6	30108004	240271	挡圈	ring	1
7	301S11007	35827	挡圈螺钉	screw	1
8	301S20001	7066	护罩座固定螺钉	screw	1
9	30127005	252536	弹簧	spring	1
10	001005	240129	O型圈 7.5×1.8	o ring	1
11	3011201100	252539A91	左板组件	bracket	1
12	S01004	7019	螺钉 M4×7.8	screw	5
13	30122021	240162	油封堵	plug	1
14	3011201300	252664-91	调节扳手组件	lever assy	1
15	30112015	252538	调节板	scale plate	1
16	S01003	7021	螺钉 M4×12	screw	2
17	30203019	240124	调节套	spacer	2
18	20109005	210171	调节滑块	stopper	2
19	301S11008	2905	螺钉	screw	2
20	W01006	201185	垫圈 4	washer	2
21	301S16004	210167	螺母	nut	1
22	301S30007	5486	调节扳手螺钉	screw	1
23	30128014	211301	垫圈	washer	1
24	301S11023		挡圈螺钉(短)	screw	1

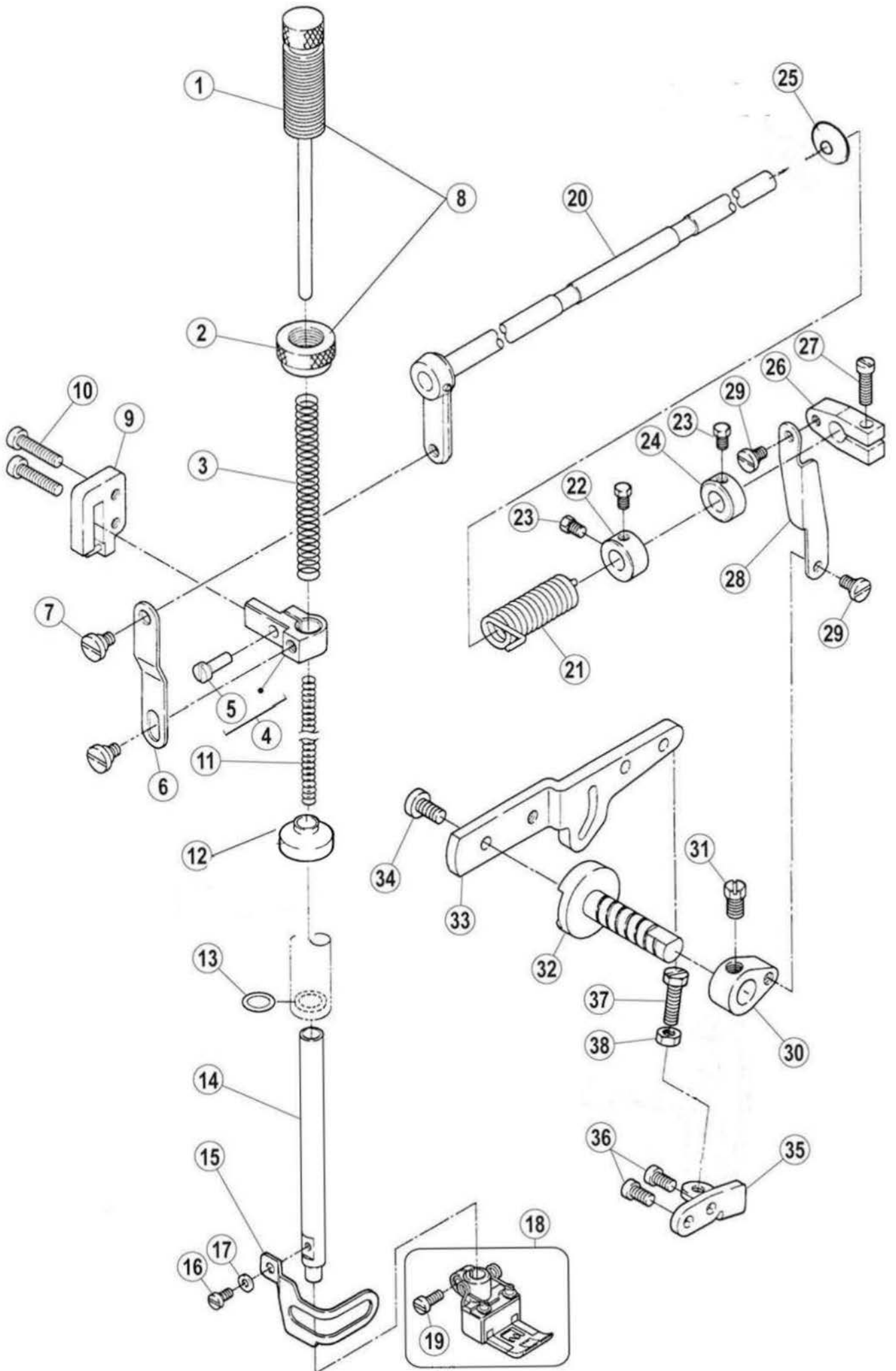

十一、压脚部件(Presser form assemblies)

序号 Ref.No	公司件号 Part No	参考件号 Ref. Part. no	名称	Description	数量 Number
1	3013002502	253000-91	调压螺丝	adjusting bar	1
2	301S16005	253003	调节母	nut	1
3	30127006	240112	调压弹簧	spring	1
4	30104017	206139	压脚轧头	presser bar clamp	1
5	S01003		螺钉 M4×12	screw	1
6	30112016	206157	压脚轧头连接板	link	1
7	301S20007	5386	螺钉	screw	2
8	3013002500		调压螺杆组件	adjusting bar assy	1
9	3010901700	253005-91	导块销簧组件	guide assy	1
10	S11025	7025	螺钉 M4×12	screw	2
11	30127008	240113	调压弹簧	spring	1
12	30722004	2530530	橡皮圈	oil guard	1
13	001006	240095	O型圈8.5×1.8	o ring	1
14	30102020	253004	压脚轴	presser shaft	1
15	30112017	253028	压脚护罩	finger guard	1
16	S01006	7010	螺钉 M3×4.5	screw	1
17	W01002	202875	垫圈3	washer	1
18	30116020	257460-40	240压脚	presser foot assy	1
	3011601300		356压脚	presser foot assy	1
	3011601400		364压脚	presser foot assy	
	30116005		356压脚 (02型)	presser foot assy	1
	30116006		364压脚 (02型)	presser foot assy	1
	30116003		356压脚 (05型)	presser foot assy	1
	30116004		364压脚 (05型)	presser foot assy	1
19	301S11010	1170-3	螺钉	screw	1
20	30102021	253008-1	抬压轴	shaft	1
21	30127009	253010	抬压轴簧	spring	1
22	30108005	206156	挡圈	ring	1
23	301S12001	5084	螺钉	screw	3
24	30108006	192024	挡圈	ring	1
25	30722004	253008-4	油封	oil seal	1
26	30104019	206149	抬压曲柄 I	bell crank(upper)	1
27	301S11011	5187	螺钉	screw	1
28	30112018	253011	抬压曲柄连接板	link	1
29	301S20008	5184	螺钉	screw	2
30	30104020	206148	抬压曲柄 II	bell crank(lower)	1
31	301S20013	41386	螺钉	screw	1
32	30102022	253013	抬压轴	shaft	1
33	30112019	253014	抬压轴扳手	lever	1
34	S01011	7028	螺钉 M5×10	screw	1
35	30112020	253015	抬压曲柄座	bracket	1
36	S01004	7019	螺钉M4×7.8	screw	2
37	S01016	4549	螺钉M5×17	screw	1
38	N01004	4805	螺母M5	nut	1

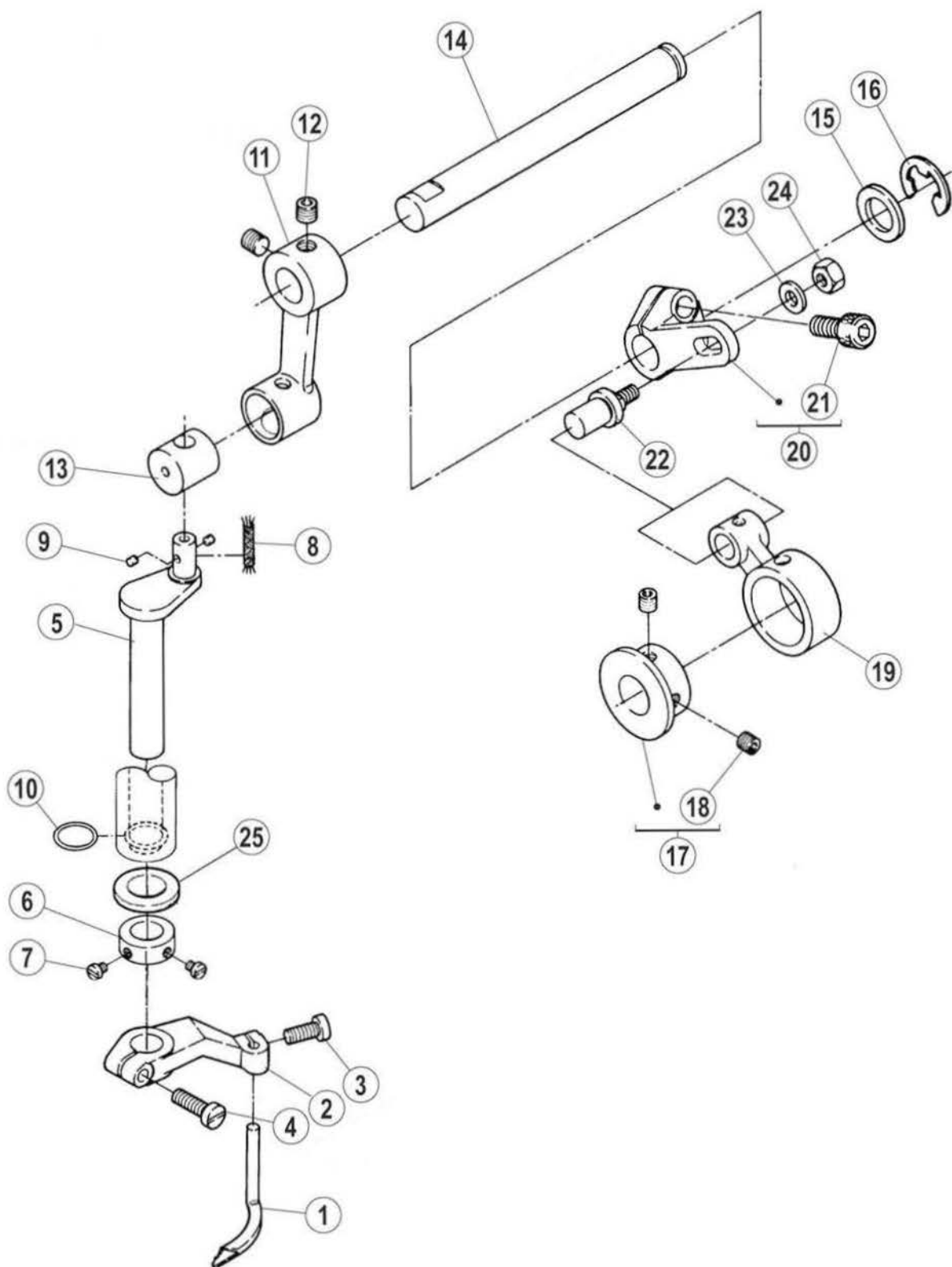

十二、 喂针部件(Needle feeding assemblies)

序号 Ref.No	公司件号 Part No	参考件号 Ref. Part. no	名称	Description	数量 Number
1	30117005	257565	喂针	spreader	1
2	30104022	254516	喂针架	lever/assy	1
3	S01005	7020	螺钉 M4×10	screw	1
4	S01017	7022	螺钉 M4×14	screw	1
5	30102023	254508	摆动轴	crankshaft	1
6	20108006	212039	挡圈	collar	1
7	201S11033	S071	挡圈螺钉	screw	2
8	20123021	202176	油线	oil wick	1
9	30123008	207925	摆动轴油孔毛毡	felt	2
10	001008	233020	O型圈 9×1.8	o ring	1
11	30105013	254506	喂针摆动连杆	crank	1
12	S10029	4547	螺钉 M6×0.75×5	screw	2
13	30126005	254507	喂针摆动销	block	1
14	30102024	254519	摆动连杆轴	shaft	1
15	30128015	206180	摆动连杆轴垫圈	washer	1
16	H05004	306671	挡圈12	ring	1
17	30110007	254501A	喂针凸轮	eccentric assy	1
18	S10002	4514	螺钉 M5×5	screw	2
19	400059	254511	喂针连杆	connection	1
20	30104024	254503	喂针摆动曲柄	crank	1
21	S05002	4534	螺钉 M6×0.75×15.2	screw	1
22	30126006	254504	连杆销	screw	1
23	30128032	240062	垫圈	washer	1
24	N01004	4805	螺母 M5	nut	1
25	30128018		垫圈	washer	1

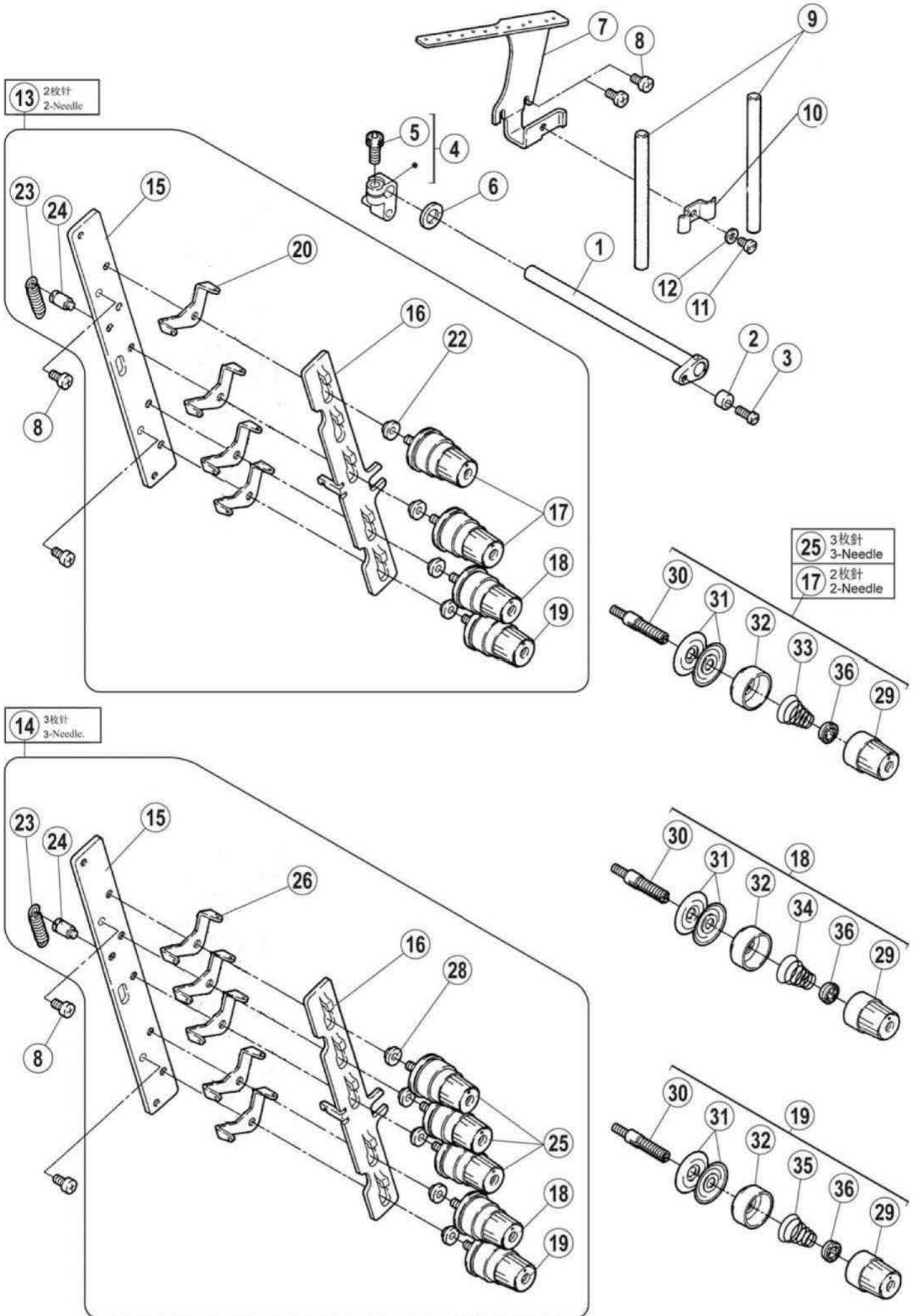

十三、 松线部件(Thread loosing assemblies)

序号 Ref.No	公司件号 Part No	参考件号 Ref. Part. no	名称	Description	数量 Number
1	3010403200	254000-91	松线曲柄II	lever	1
2	30103040	254022	轴套	spacer	1
3	301S11013	12055	轴套紧固固定螺钉	screw	1
4	3010403100	254003B91	松线曲柄I	crank	1
5	S05005	4531	螺钉 M5×12	screw	1
6	W01010	202868	垫圈 8	washer	1
7	30113001	254008	过线架	thread guide	1
8	S01004	7019	螺钉 M4×7.8	screw	4
9	30102026	192120	夹线柱	pipe	2
10	30112021	254009	压板	bracket	1
11	S01002	7017	螺钉 M4×6.5	screw	1
12	W01001		垫圈 4	washer	1
13	3011300300	254023C9U	二针过线组件	tension control mechanism	1
14	3011304200	254023E9U	三针过线组件	tension control mechanism	1
15	30113003	254019	过线板	bracket	1
16	30112022	244021	过线调节板	thread releaser	1
17	3011300400	254010A9U	调线组件（弱）	tension spring assy	2
18	3011300500	254010B9U	调线组件（中）	tension spring assy	1
19	3011300600	254212C9U	调线组件（强）	tension spring assy	1
20	30113007	254020	二孔过线板I	thread guide	4
22	30103041	206202	调节套	spacer	4
23	30127010	306301	调节板簧	spring	1
24	301S30009	5447	调节板螺钉	screw	1
25	3011300400		调线组件（弱）	tension spring assy	3
26	30113007	254020	二孔过线板I	thread guide	5
28	30103041	206202	调节套	spacer	5
29	301S16006	208447-UA	调压螺母	knob	1
30	301S30010	1817-2A	夹线杆	screw stud	1
31	30128016	210319	夹线片	tension disc	2
32	30111005	208450-UA	调压止动盖	spring shield	1
33	30127011	201037	调压簧（强）	spring (heavy)	3
34	30127012	201086	调压簧（中）	spring (medium)	1
35	30127013	201068	调压簧（弱）	spring (light)	1
36	30111006	208448	调压止动套	ratchet	1

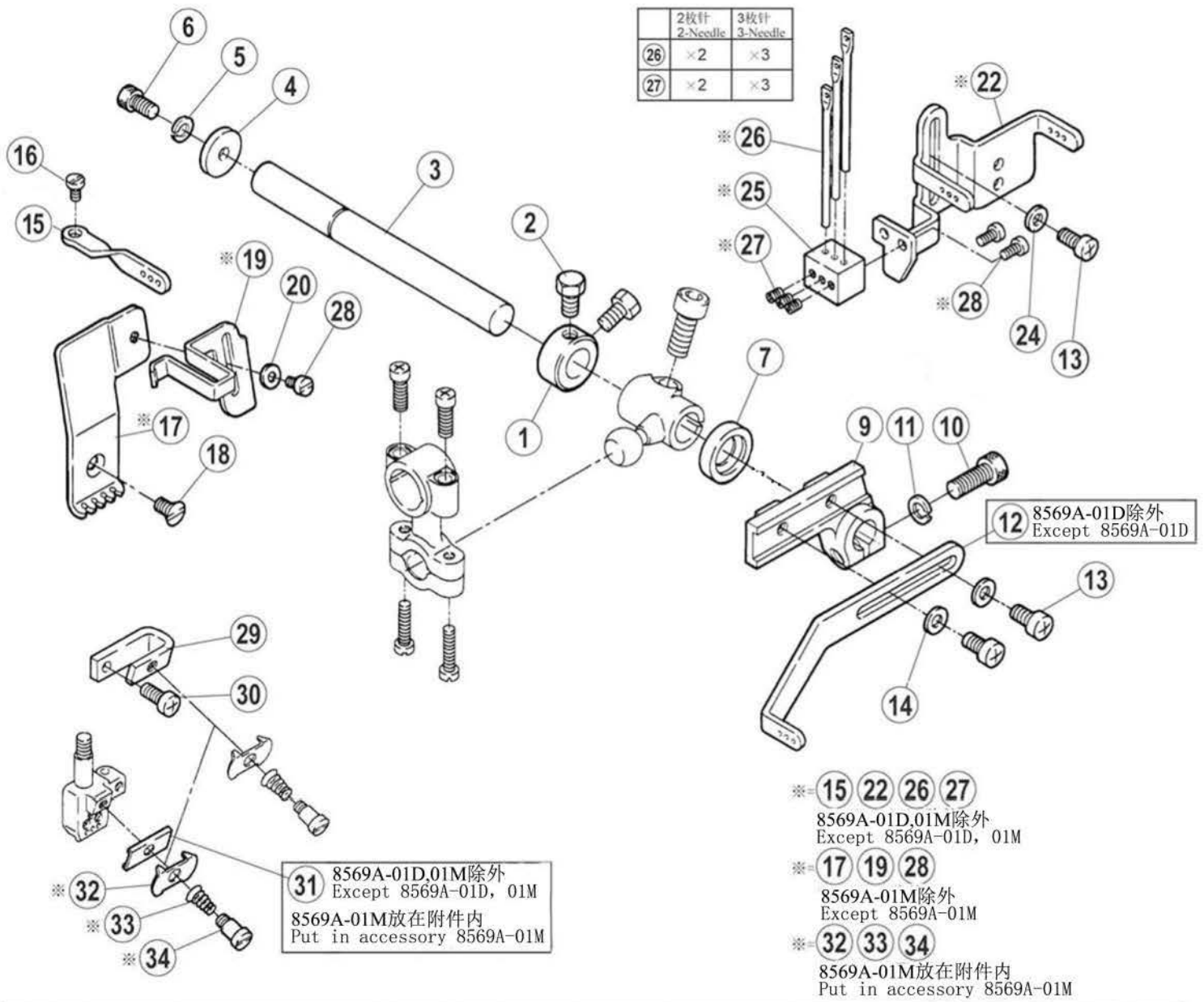

8569A Series

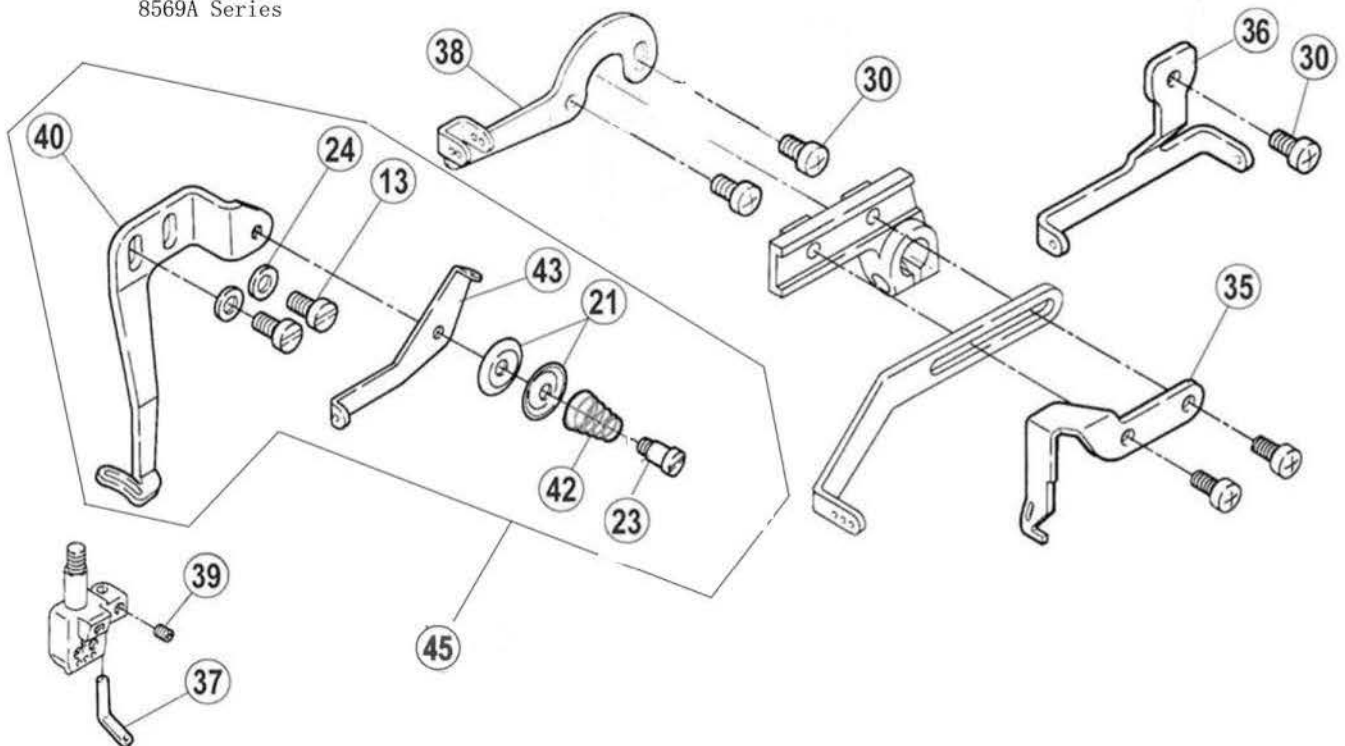

十四、 过线部件(Thread loosing assemblies)

序号 Ref.No	公司件号 Part No	参考件号 Ref. Part. no	名称	Description	数量 Number
1	20608003	240201	挡圈	ring	1
2	301S12001	5084	曲柄螺钉	screw	2
3	30102028	253503	过线座轴 (中轴)	shaft	1
4	30128019	204107	垫片	washer	1
5	W02002	201252	垫圈 4	washer	1
6	S05048	4527	螺钉M4×10	screw	
7	20622019		油封	plug	1
9	30101018	253504	过线座	lever	1
10	S05004	4501	螺钉 M5×14	screw	1
11	W02001	303067	垫圈 5	washer	1
12	30113009	253505A	长过线板	thread take-up	1
13	S01004	7019	螺钉 M4×7.8	screw	5
14	W01001	303448	垫圈4	washer	2
15	30113010	253507	三孔过线	thread guide	1
16	S01006	7009	螺钉 M3×4.5	screw	1
17	30113011	253508A	过线板	thread guide	1
18	206S30016	7170	螺钉M4×4.5	screw	1
19	30112023	253509A	护线罩	thread support	1
20	30128034	202588	垫圈	washer	1
21	20112033	137108	夹线片	thread retainer	2
22	30112027	253544	硅油盒固定架	thread guide	1
23	301S30035		螺钉	screw	1
24	W01001	303448	垫圈 4	washer	1
25	30113012	253545	针杆过线座	holder	1
26	30113013	234521	过线杆	thread guide	3
27	S10001	4535	螺钉 M3×4	screw	3
28	S01006	7009	螺钉 M3×4.5	screw	2
29	30112024	253516	U形夹线座	thread tension bracket	1
30	S01001	7018	螺钉 M4×7	screw	4
31	30112025	234561	夹线板	thread guide	1
32	30112026	253593	压线板	thread retainer	1
33	30127014	253517	调压簧	spring	1
34	301S20009	W09070-2	调线螺钉	screw	1
35	30112028	353506	长过线压板	thread take-up	1
36	30112030	253515	过线板	thread guide	1
37	30112033	253511	喂针小过线	thread guide	1
38	30112029	253514	喂针过线	thread guide	1
39	S10005	4554	螺钉 M3×3	screw	1
40	30112031	253548	喂针过线板	thread guide	1
42	30127016	211388	夹线簧	spring	1
43	30112032	253547	喂针二眼过线	thread guide	1
45	3011203200		喂针二眼过线组件	thread guide	1

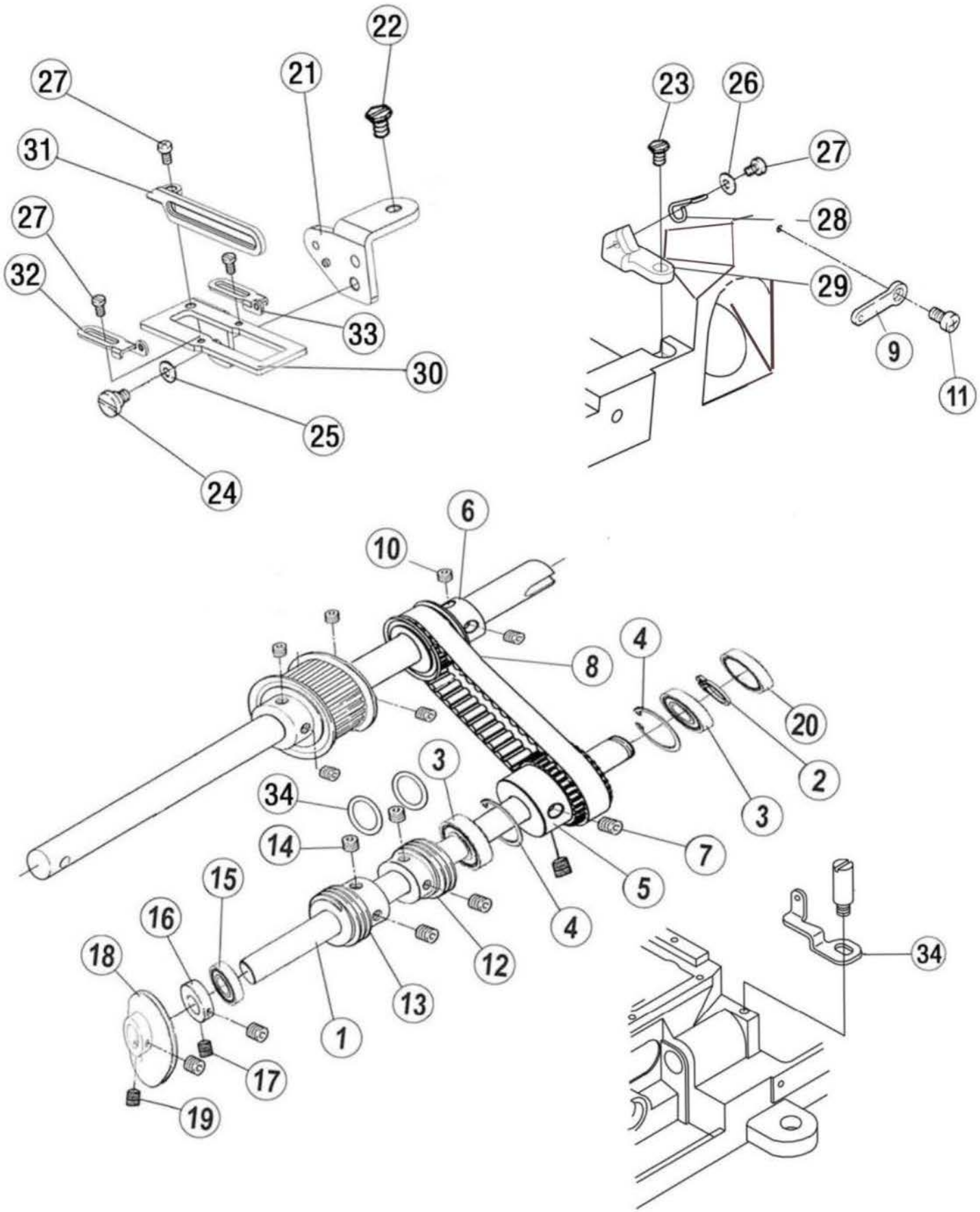

十五、打线凸轮外移部件(Outside cam assemblies)

序号 Ref.No	公司件号 Part No	参考件号 Ref. Part. no	名称	Description	数量 Number
1	30102065		打线凸轮轴	shaft	1
2	H03004		挡圈 12	ring	1
3	B04017		轴承 6001Z	bracket	2
4	H01011		挡圈 28	ring	2
5	30125004		小同步带轮1	small gear1	1
6	30125005		小同步带轮2	small gear2	1
7	S10003		螺钉 M6×0.75×5	screw	4
8	30135005		小同步带	small timing belt	1
9	30113016		过线	thread guide	1
10	S12005		螺钉	screw	2
11	S01001		螺钉M4×7	screw	1
12	30103075		凸轮轴右回油套	recycle sleeve (right)	1
13	30103076		凸轮轴左回油套	recycle sleeve (left)	1
14	S10014		螺钉 M5×4	screw	4
15	B06004		轴承 6801RS	bracket	1
16	20108002		挡圈	washer	1
17	201S15003		挡圈螺钉	screw	2
18	30103071		打线凸轮组件	thread takeup	1
19	S10002		螺钉 M5×5	screw	2
20	30122100		油封	plug	1
21	30112070		打线架支座	bracket	1
22	L02001		螺钉 M4×8	screw	1
23	S01004		螺钉 M4×7.8	screw	1
24	301S20020		螺钉	screw	1
25	W03007		垫圈	washer	2
26	W01002		垫圈	washer	1
27	207S11020		螺钉 M3×4	screw	4
28	30727006		过线簧	flat spring	1
29	30112087		定位板	bracket	1
30	30112069		打线架	bracket	1
31	30112085		打线片	thread guide	1
32	30313019		过线片(左)	thread guide (left)	1
33	30313020		过线片(右)	thread guide (right)	1
34	30113017		弯针过线架	thread guide	1

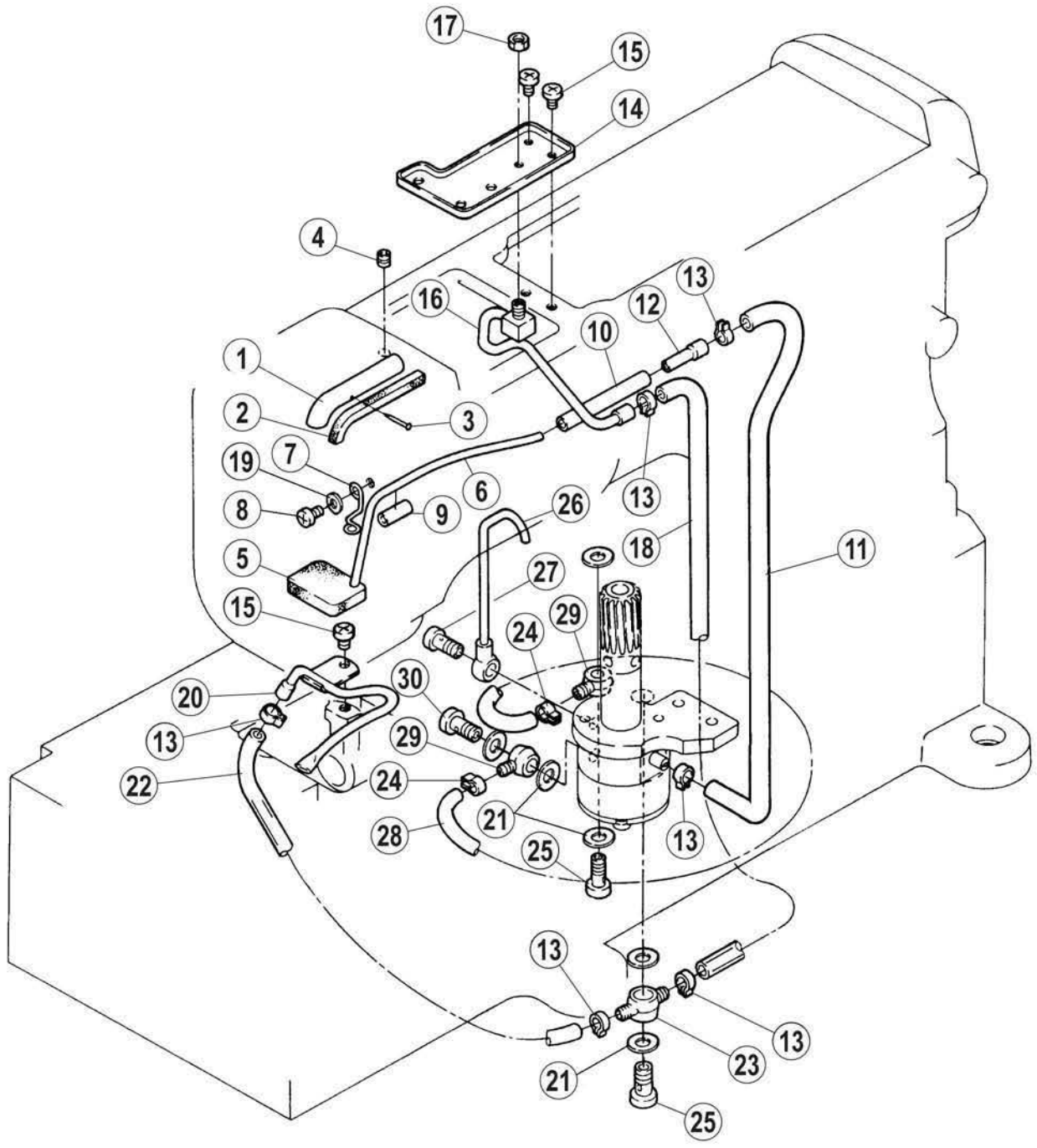

十六、 润滑部件(Lubrication assemblies)

序号 Ref.No	公司件号 Part No	参考件号 Ref. Part. no	名称	Description	数量 Number
1	30121012	255003	铜油管	oil pipe	1
2	30123010	240136	油毡	felt	1
3	30126008	210766	销钉	pin	1
4	S10002	4514	螺钉 M5×5	screw	1
5	30123009	255021	油毡	felt	1
6	3012101400	255039	细油管	pipe	1
7	30127019	200136	压簧	latch	1
8	S01004	255005	螺钉 M4×7.8	screw	1
9	30121007	240143	油管	tube	1
10	30121005	240144	油管	tube	1
11	30121022	240135	Φ4×Φ6油管	tube	1
12	30136002	255038	油管接头	joint	1
13	20129002	202199	油管卡簧	clamp	6
14	30112039	255006	接油盘	oil guard	1
15	S01002	7017	螺钉 M4×6.5	screw	3
16	3012101500	255007-91	喷油管组	oil distributor	1
17	N01001	4821	螺母 M4	nut	1
18	30121022	240134	Φ4×Φ6油管	tube	1
19	W01001	303448	垫圈 4	ring	1
20	30121009	255010-91	喷油管	oil distributor	1
21	20122033		垫片	washer	6
22	30121021	240270	Φ5×Φ7油管	tube	1
23	30136005	200136	双头油管接头	joint	1
24	30129006	202199	油管卡簧(大)	clamp	2
25	301S30013	200152	过油螺钉	joint screw	2
26	30136003	255035-91	铜油管接头	pipe	1
27	301S30012	255037	油管螺钉	screw	1
28	30121021	205113A	Φ5×Φ7油管	tube	1
29	30136001	200136	油管接头	joint	2
30	201S30004	200152	过油螺钉	joint screw	1

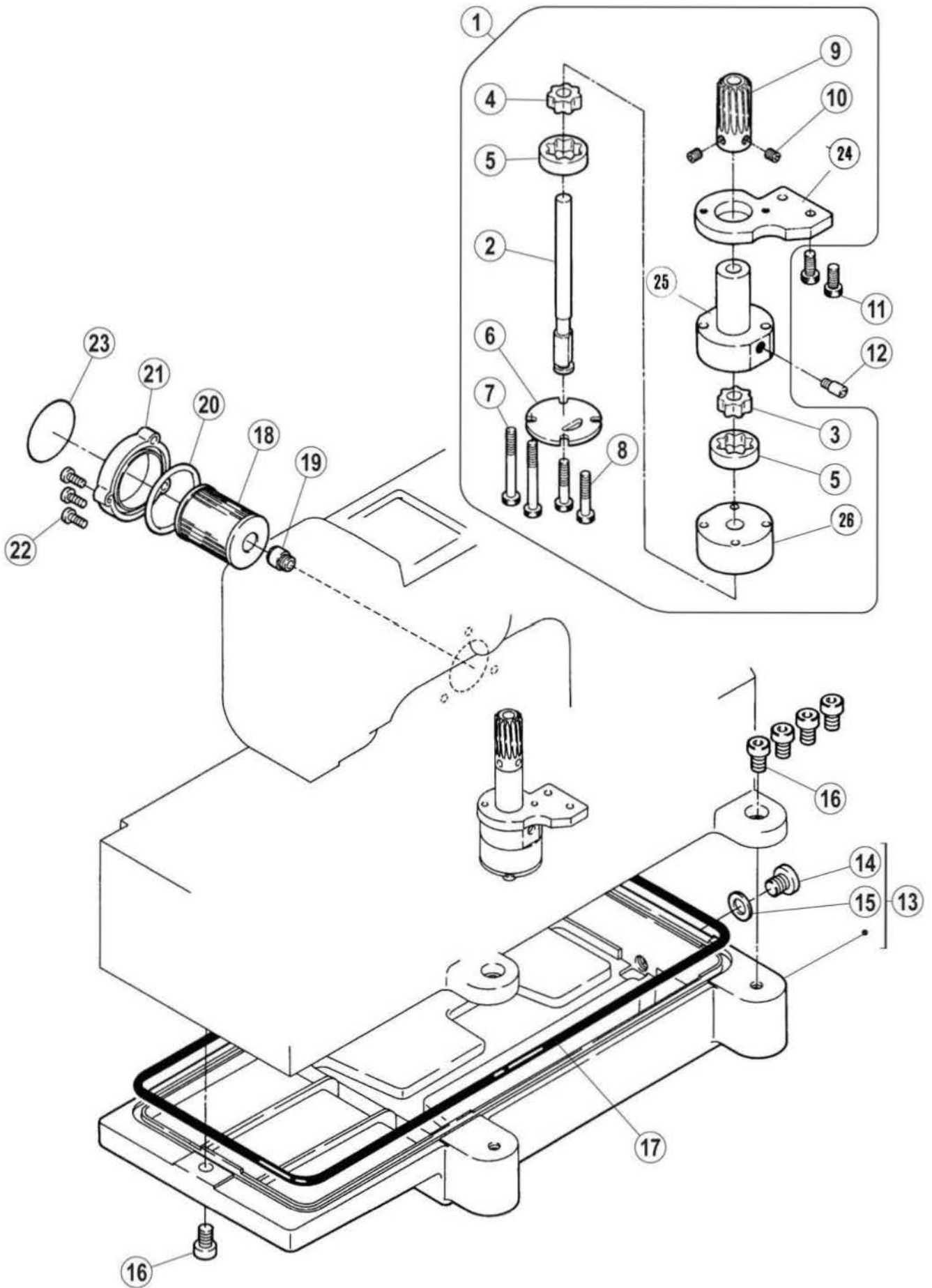

十七、 油泵部件(Oil pump assemblies)

序号 Ref.No	公司件号 Part No	参考件号 Ref. Part. no	名称	Description	数量 Number
1	3012000100	255040-91	油泵组件	oil pump assy	1
2	30102031	255024	油泵轴	shaft	1
3	30120004	255025	五星轮	rotor	1
4	30120007	255026	五星轮	rotor	1
5	30120005	255027	五星套	rotor	2
6	30120008	255028	油泵盖	cover	1
7	301S20011	7105	油泵螺钉	screw	2
8	S05006	7026	螺钉 M4×25	screw	2
9	30125003	255019	油泵蜗轮	worm wheel	1
10	S10002	4514	螺钉 M5×5	screw	2
11	S05004	4501	螺钉 M5×14	screw	2
12	301S30014		过油螺钉	joint screw	1
13	30101023	255000	油盘	oil reservoir	1
14	301S11015	5138B	堵油螺钉	screw	1
15	20528014	202287A	垫圈	washer	1
16	S05007	4504	螺钉 M8×20	screw	5
17	30122025	255001	油盘密封圈	o ring	1
18	20136001	206233	滤油器	filter element	1
19	301S30016	210200	螺钉	bracket/filter element	1
20	001010	206431	O型圈 38.7×3.55	o ring	1
21	300140	210201-SD	滤油器盖	cover	1
22	S01003	7021	螺钉 M4×12	screw	3
23	30131004	9A3002	提示说明	filter seal	1
24	30120002		油泵固定板	fixed plank	1
25	30220001		油泵体 (上)	oil pump (up)	1
26	30131004		油泵体 (下)	oil pump (down)	1

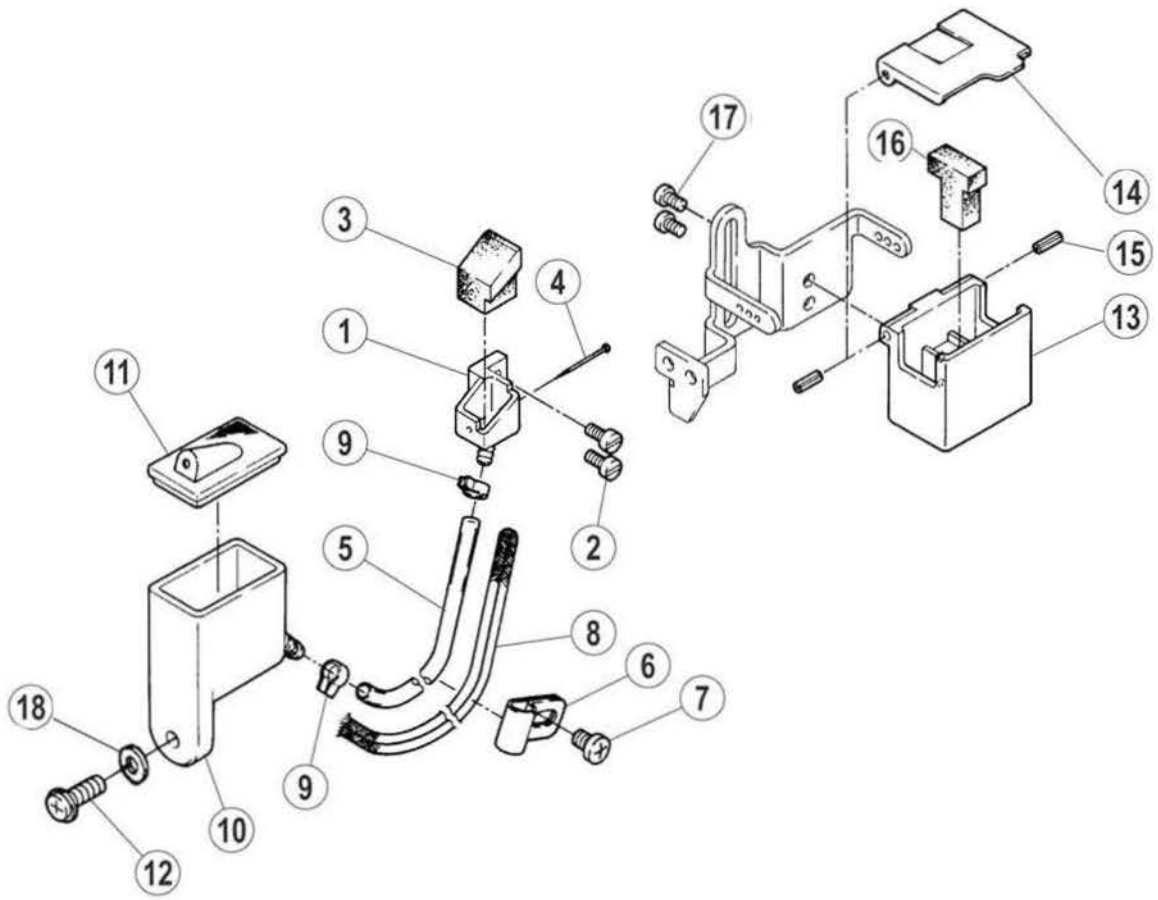

十八、 硅油盒装置部件(Silicon oil delice assemblies)

序号 Ref.No	公司件号 Part No	参考件号 Ref. Part. no	名称	Description	数量 Number
1	30101027	255013	机针冷却器	needle cooler (lower)	1
2	S01015	7010	螺钉 M3×5	screw	2
3	30123012	255014	油棉	felt	1
4	30126009	210766	销	pin	1
5	30121021	240117	Φ5×Φ7油管	tube	1
6	30127020	206115	油管压簧片	bracket	1
7	S01004	7019	螺钉 M4×7.8	screw	1
8	20123021	202175	油线	oil wick	1
9	30129006	202199	油管卡簧(大)	clamp	2
10	30101026	255015	下硅油盒	silicone oil reservoir(lower)	1
11	30122026	255016	下硅油盒盖	cap	1
12	S01005	7020	螺钉 M4×10	screw	1
13	300141	207066-UD	上硅油盒(喷漆)	silicone oil reservoir(upper)	1
14	30112040	207067-UD	硅油盒盖	cap	1
15	P03008	206781	销 2×6	pin	2
16	30123011	207068	硅油棉	felt	1
17	S01006	7009	螺钉 M3×4.5	screw	2
18	W01001	303448	垫圈 4	washer	1

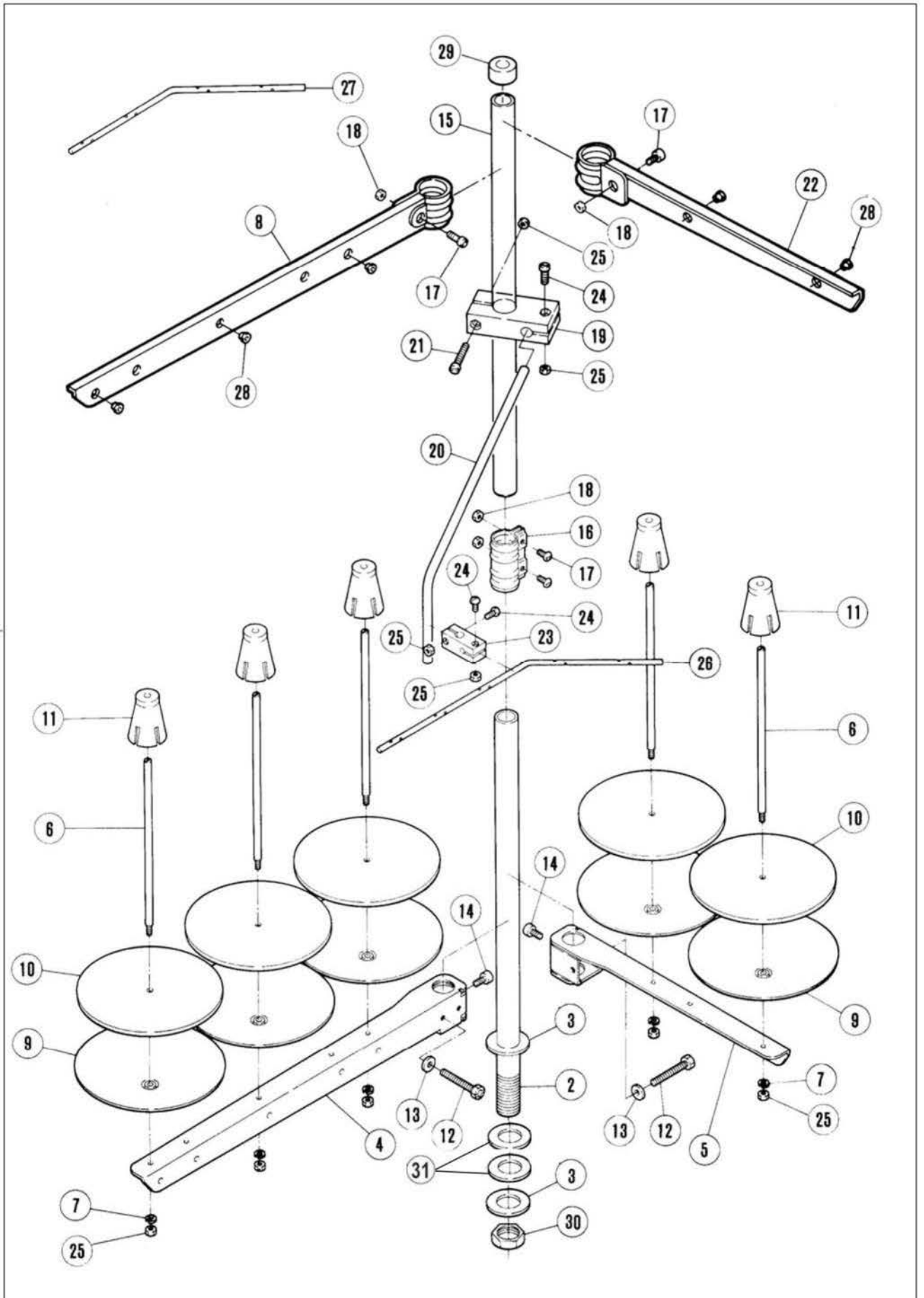

十九、 线架部件(Thread apool assemblies)

序号 Ref.No	公司件号 Part No	参考件号 Ref. Part. no	名称	Description	数量 Number
1	3013102700		线架组件	thread assy	1
2	30102032	503-SA	线架下捧	thread bar(loer)	1
3	30128024	509	垫圈	washer	2
4	30101028	505SA	长线架	bracket(3-spool)	1
5	30101029	505SA	短线架	bracket(3-spool)	1
6	20131006	380A	线捧	spool pin	5
7	W02002	201252	垫圈 4	washer	5
8	30101030	527-SA	长过线架	bracket(3-spool)	1
9	20631025	381-SA	线托盘	spool tray	5
10	20631024	507	托盘垫	cushion	5
11	20131008	382-SA	线固定套	spool retaining fin	5
12	L02004	7102	螺钉 M6×34	screw	2
13	W01003	512	垫圈 6	washer	2
14	S04001	4022	螺钉 M6×10	screw	2
15	30102034	502-SA	线架上捧	thread bar(upper)	1
16	30129005	504-SA	锁紧卡固	joint	1
17	S04002	4021	螺钉 M5×16	screw	4
18	N01004	4805	螺母 M5	nut	4
19	30111008	383-SA	棒架	bracket	1
20	30113018	384	导线棒	thread guide bar	1
21	S04003	4014	螺钉 M4×25	screw	1
22	30101031	527ASA	短过线架	bracket	1
23	20631017	233-SA	固定器	holder	1
24	S04004	4012	螺钉 M4×15	screw	3
25	N01005	4803	螺母 M4	nut	9
26	20131036	293A	过线捧	thread guide bar(5-spool)	1
27	20631019	293B	过线捧	thread guide bar(6-spool)	1
28	30103045	506	过线套	thread guide	5
29	30122027	386	棒帽	rid cap	1
30	N01026	5476	螺母 M18×1.5	screw	1
31	30128062		橡胶垫圈	washer	2

台板部件 (放在附件内)
 machine table mechanism (put in accessory)

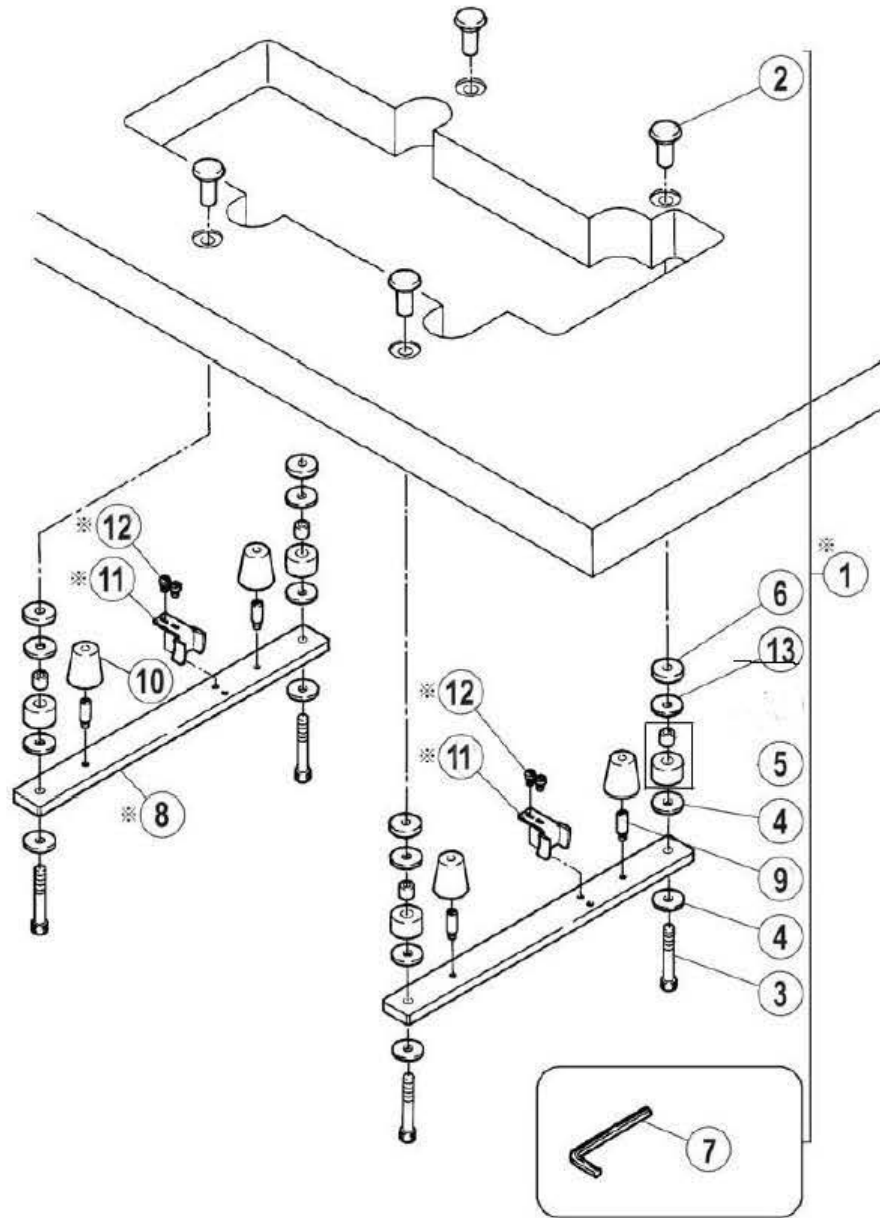

二十、油盘托板部件(Oil plate assemblies)

序号 Ref.No	公司件号 Part No	参考件号 Ref. Part. no	名称	Description	数量 Number
1	3010103200	9048	安装螺钉 (一套)	screw(set)	1
2	20131028	206336	托盘固定螺母	nut	4
3	20131027	4512	托板内六角螺钉	bolt	4
4	20131029	206337	大垫圈	washer	8
5	20131030	205764	防振套	rubber cushion	4
6	30122031	205467	减震垫圈	spacer	4
7	20131056	272	内六角扳手 (6mm)	allen key driver/6mm	1
8	400247	259000	油盘托板	rest board	2
9	301S30018	7093	螺钉	screw	4
10	30122029	206338	油盘减振垫	rubber cushion	4
11	30112041	206329	链条挡板	treadle chain guide	2
12	S01011	7027	螺钉 M5×10	screw	4
13	20131029	206337	大垫圈	washer	8

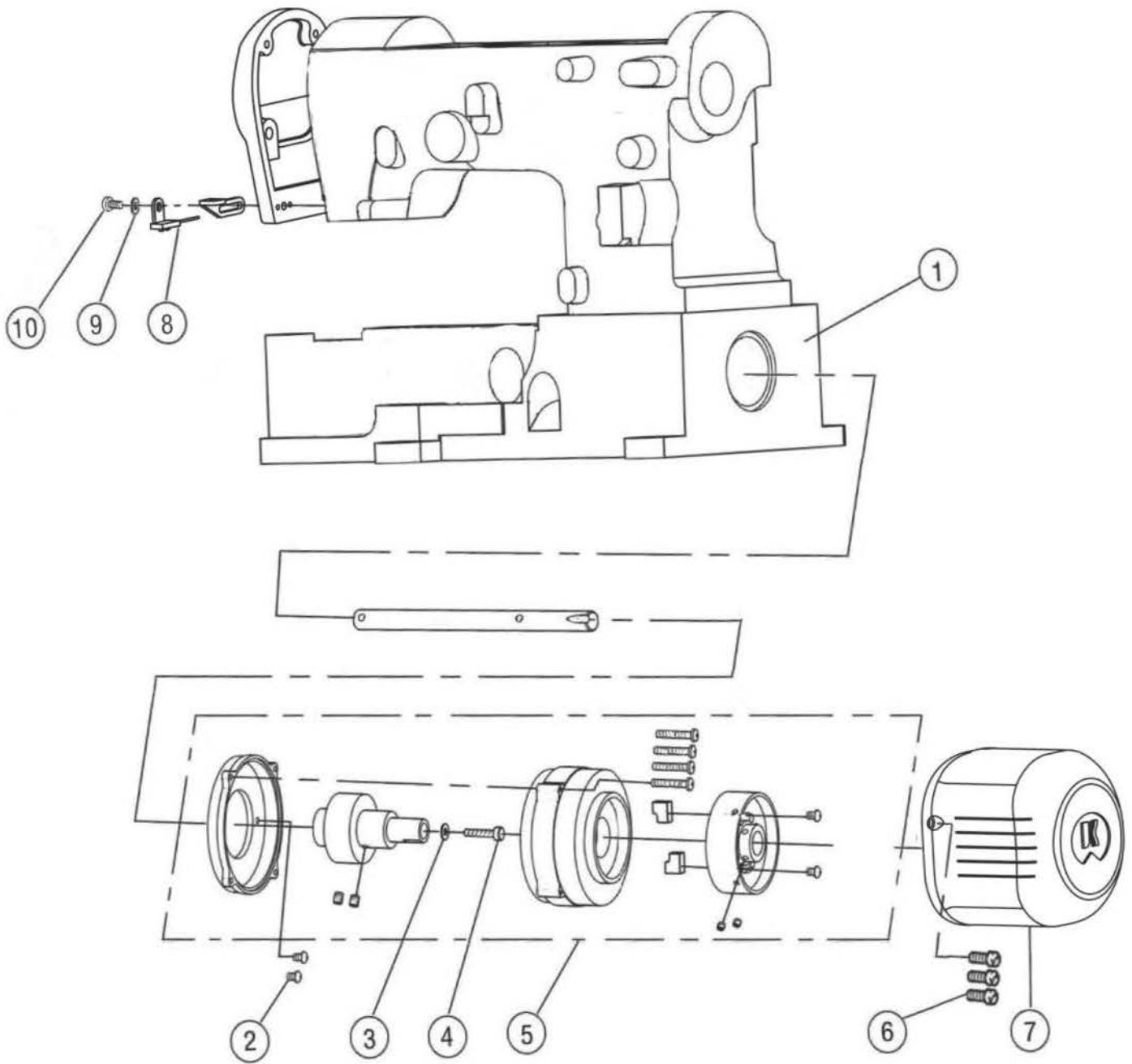

二十一、DI部件专用件(DI specific parts)

序号 Ref.No	公司件号 Part No	参考件号 Ref. Part. no	名称	Description	数量 Number
1	301780	250215-2	机壳(喷漆)	machine frame	1
2	S04010		螺钉M4×5.5	screw	2
3	W02004		垫片	washer	1
4	114S30001		螺栓	screw	1
5	3013300300		电机组件	plulley	1
6	S01011		螺钉	screw	3
7	30111031		电机罩壳	plulley cover	1
8	2013001000		LED灯组件	LED light	1
9	W01001		垫片	washer	1
10	S04019		螺钉M4×12	screw	1

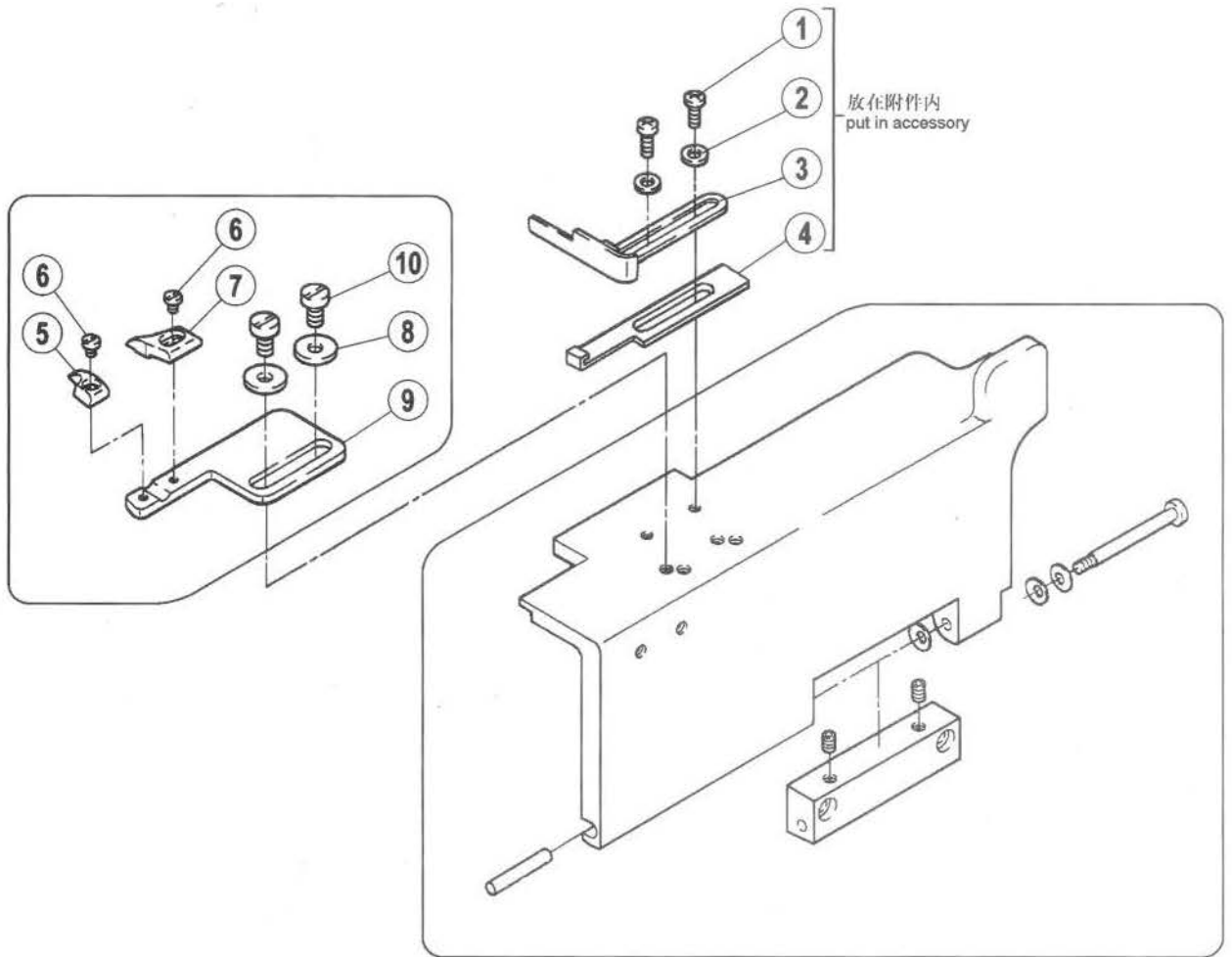

二十二、 03、08专用部件(03、08 specific parts)

序号 Ref.No	公司件号 Part No	参考件号 Ref. Part. no	名称	Description	数量 Number
1	301S11024		滑块导座螺钉	screw	2
2	W01001		垫圈4	washer	2
3	30112065		缝料挡板1	fabric guide	1
4	30112066		缝料挡板2	fabric guide	1
5	30109020		盖缝附件1	fabric guide	1
6	S01036		螺钉 M3×3	screw	2
7	30109021		盖缝附件3	fabric guide	1
8	W01009		垫圈5	washer	2
9	30112064		盖缝附件2	bracket	1
10	S01011		螺钉 M5×10	screw	2

8569A-01D

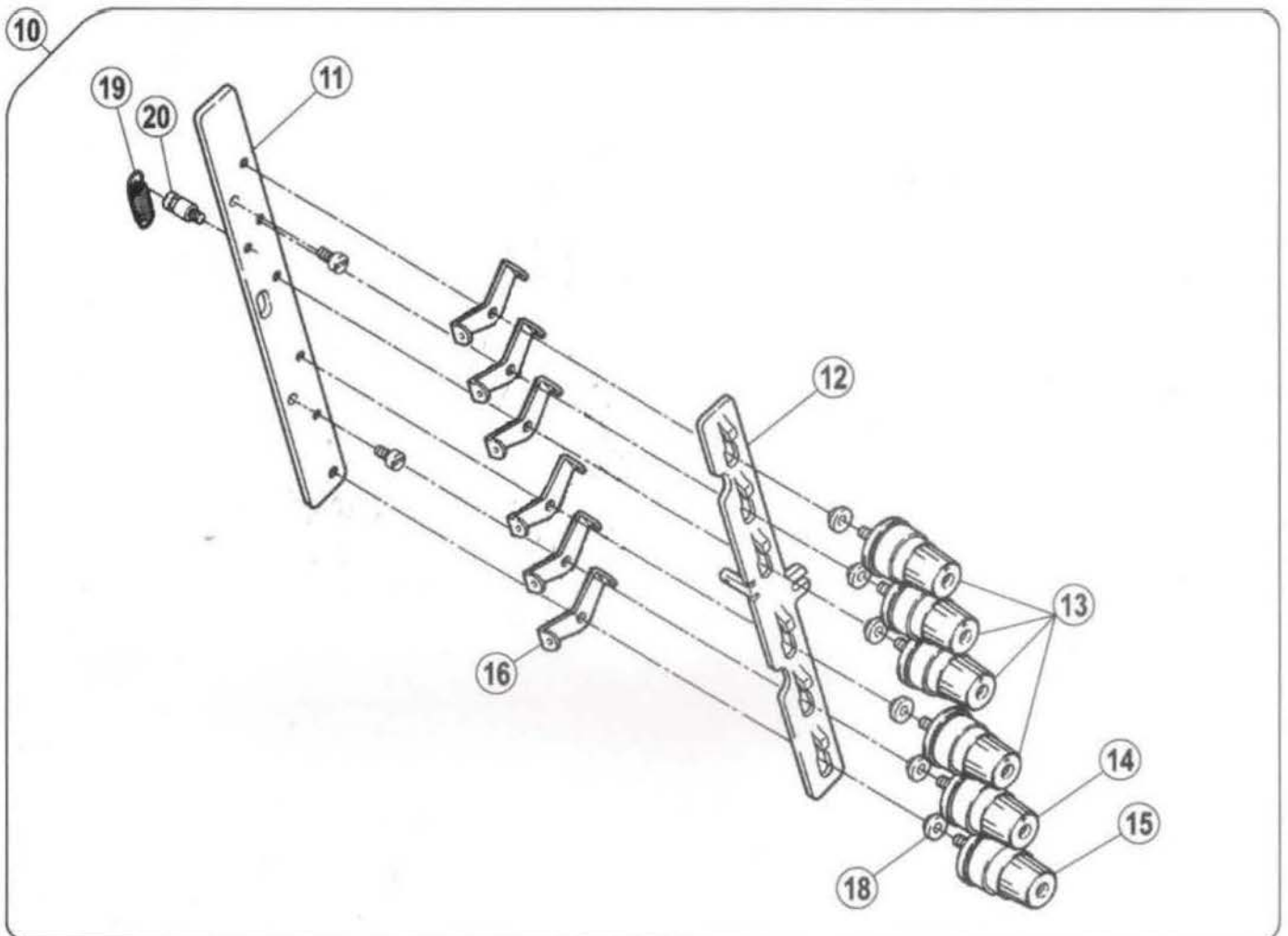
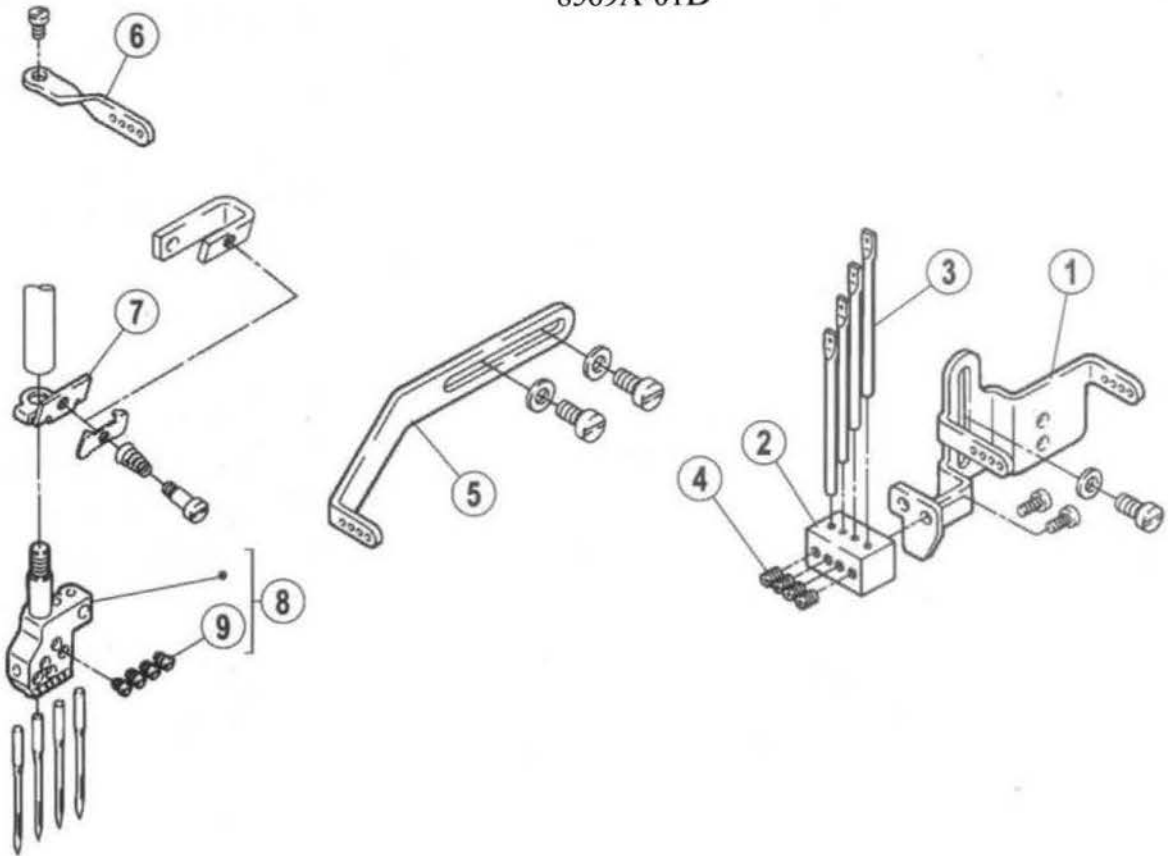

二十三、 01D专用部件(01D specific parts)

序号 Ref.No	公司件号 Part No	参考件号 Ref. Part. no	名称	Description	数量 Number
1	30112151		硅油盒固定架	thread guide	1
2	30113052		针杆过线座	holder	1
3	30113056		过线杆	thread guide	4
4	S10001		螺钉 M3×4	screw	4
5	30113053		长过线	thread take-up	1
6	30113054		四眼过线	thread guide	1
7	30113057		调子台	thread guide	1
8	30134020		针轧头	needle holder	1
9	301S17050		螺钉 M3×3	screw	4
10	3011304500		过线组件	tension control mechanism	1
11	30113031		过线板	bracket	1
12	30113029		过线调节板	thread releaser	1
13	3011300400		调线组件(弱)	tension spring assy	3
14	3011300500		调线组件(中)	tension spring assy	1
15	3011300600		调线组件(强)	tension spring assy	1
16	30113007		二孔过线板 I	thread guide	6
18	30113041		调节套	spacer	6
19	30127010		调节板簧	spring	1
20	301S30009		调节板螺钉	screw	1

8569A-02 C,02G,02H

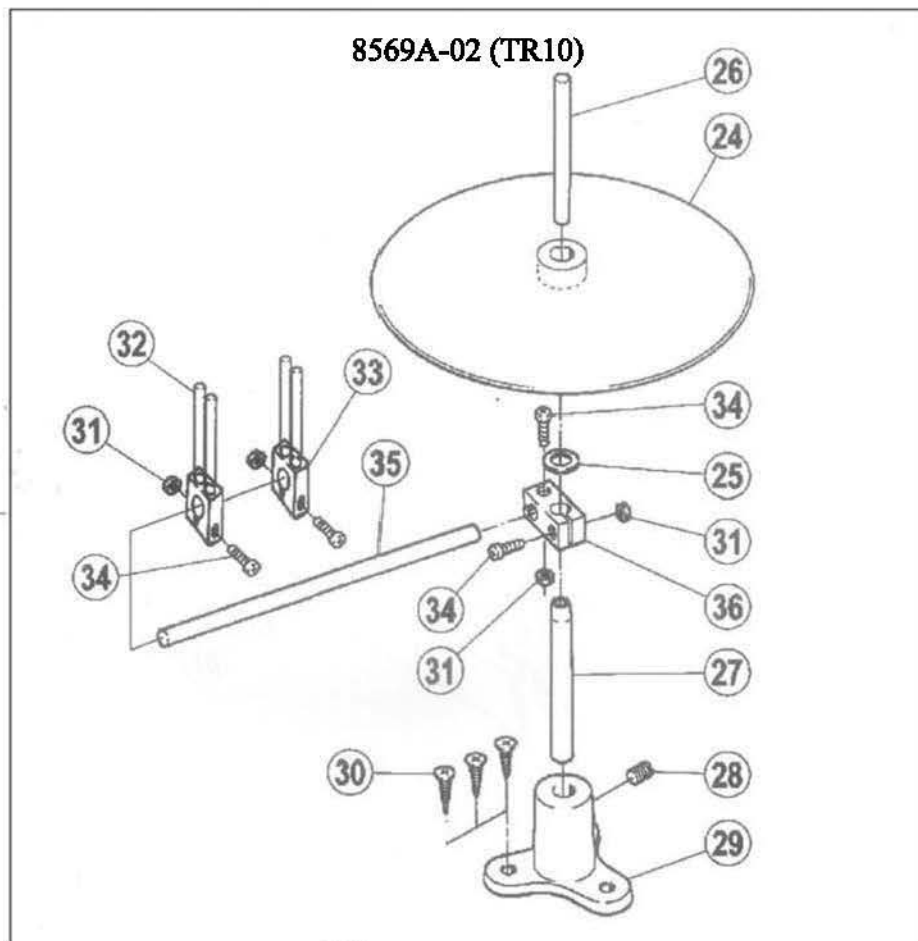
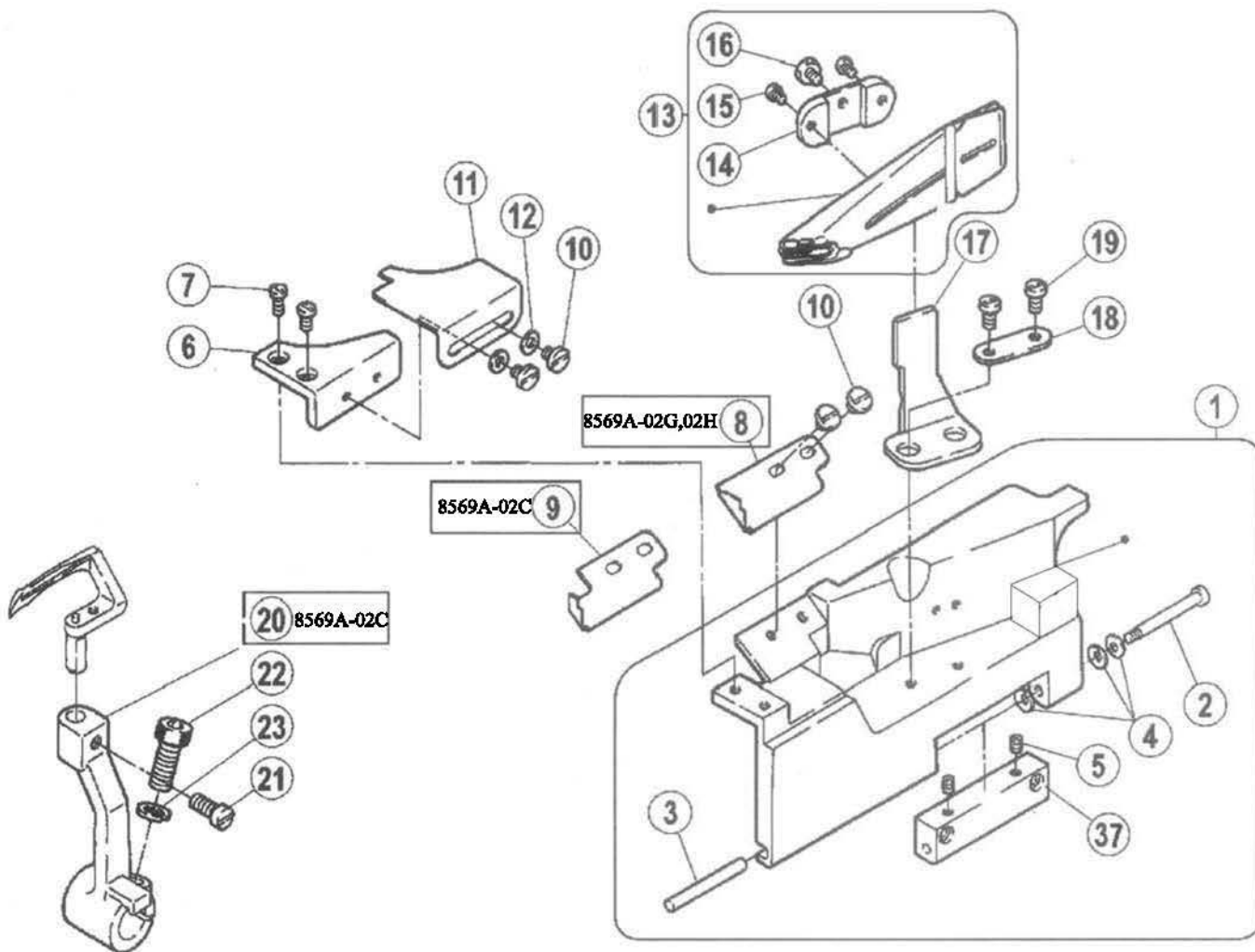

二十四、 02专用部件(02 specific parts)

序号 Ref.No	公司件号 Part No	参考件号 Ref. Part. no	名称	Description	数量 Number
1	302424	250033-SD	前罩缝台组件	front cover	1
2	301S20002	250013	前罩缝台座螺钉	screw	1
3	301S20003	250014	前罩缝台座螺钉	screw	1
4	30128002	201191	弹簧垫圈	spring	3
5	S10002		螺钉 M5×5	screw	2
6	300130	250050-SD	前缝台挡板座	front cover(small)	1
7	S01011	7028	螺钉 M5×10	screw	2
8	30112061	206601A	缝料挡板	fabric guard	1
9	30112088		缝料挡板	fabric guard	1
10	S01065	7079	螺钉 M5×6	screw	4
11	30112060	206439	前缝台挡板	auxiliary plate/front cover	1
12	W01004	204585	垫圈5	washer	1
13	3011206800		龙头组件	bracket assy	1
14	30109019	201913	龙头固定板	bracket	1
15	301S11021	5113	螺钉	screw	2
16	L02009		螺栓 M6×10	bolt	1
17	30112062	201914	龙头架	bracket	1
18	30112063	206460	龙头架垫	washer	1
19	S01011	7028	螺钉 M5×10	screw	2
20	30104011	252007-92	弯针架	looper holder assy	1
21	S01002		螺钉 M4×6.5	screw	1
22	S05004		螺钉 M5×14	screw	1
23	W02001	303067	垫圈5	washer	1
24	30111019	247-SA	带子托盘	tape disc	1
25	30128029	270	托盘垫圈	washer	1
26	30103060	253	托盘上棒	tape disc bar	1
27	30103061	250	托盘下棒	tape disc bar	1
28	S09002	1448	螺栓 M6×6	bolt	1
29	30101049	251-SA	托盘座	bracket	1
30	301S30020	4913	木螺钉	screw	3
31	N01001		螺母M4	nut	4
32	30102048	253	上夹带棒	tape disc bar	4
33	30101050	254	夹带座	holder	2
34	S04004		螺母 M4×15	nut	4
35	30113023	255	带子导座	guider post bar	1
36	30111020	256-SA	托盘导棒架	bracket	1
37	30101063	250012	前罩缝台座	bracket	1
38	3011101800		托盘组件	bracket assy	1

左縫台蓋
COVER

8569A-05S, 05T 除外
Except 8569A-05S, 05T

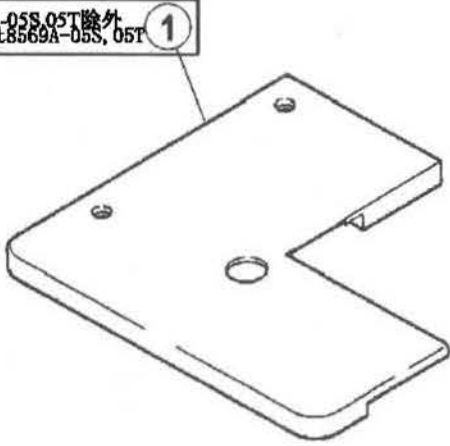

8569A-05

下軸部件
CRANKSHAFT DRIVE MECHANISM

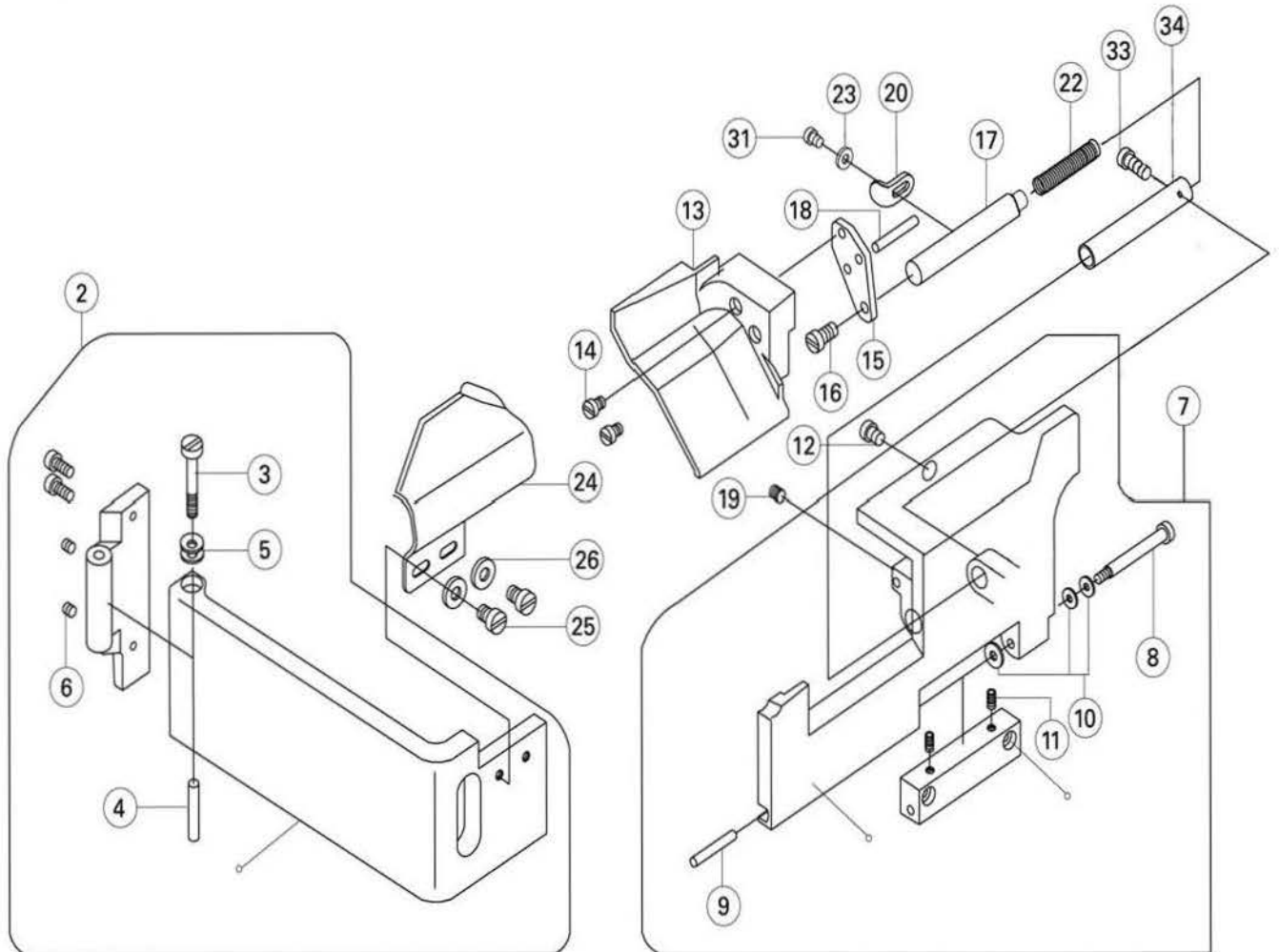
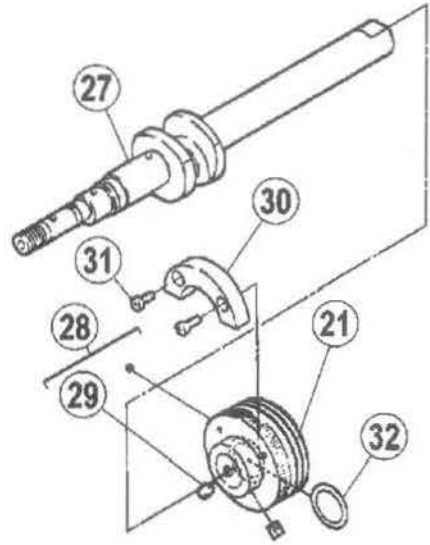

二十五、 05专用部件(05 specific parts)

序号 Ref.No	公司件号 Part No	参考件号 Ref. Part. no	名称	Description	数量 Number
1	300471	250052	左缝台盖	bed cover	1
2	300203	250035A	侧盖	side cover assy	1
3	301S20004		侧盖合扇销钉	screw	1
4	301S20005		销螺钉	pin	1
5	30128002	201191	弹簧垫圈	spring	2
6	S10001		螺钉M3×4	screw	2
7	302518	250024	前罩缝台	front cover assy	1
8	301S20002	250013	前罩缝台座螺钉	screw	1
9	301S20003	250014	前罩缝台座螺钉	pin	1
10	30128002	201191	弹簧垫圈	spring	3
11	S10006	4539	螺钉 M5×6	screw	2
12	30122015		前罩防振垫	cushion	1
13	30112045	250025-ME	前挡板	font cover(small)	1
14	S01001	7018	螺钉 M4×7	screw	4
15	30112046	250026	定位板	bracket	1
16	S01011	7028	螺钉 M5×10	screw	1
17	30102110	250027	前挡板轴	shaft	1
18	30126010	306920	平行销	pin	1
19	S10002	4514	螺钉 M5×5	screw	1
20	30112160	250028	挡板	stopper	1
21	3012400300		油封轴承	bushing	1
22	30127050	202304	弹簧	spring	1
23	W01002		垫片	washer	1
24	30112044	255517	左挡板	fabric guide	1
25	301S11020	7074	螺钉	screw	2
26	W01004	204585	垫圈5	washer	2
27	400068	250501-91	下轴	crankshaft assy	1
28	30103003	250504	前轴套	bushing	1
29	S10006	4539	螺钉 M5×6	screw	2
30	30109002	250534	下轴平衡块	balance weight	1
31	S01009		螺钉 M3×7.5	screw	3
32	001001		O型圈15×2.65	O ring	1
33	301S20026		螺钉 M3×12	screw	1
34	30103160		套筒	bushing	1

护针部件
NEEDLE GUARD MECHANISM

8569A-05

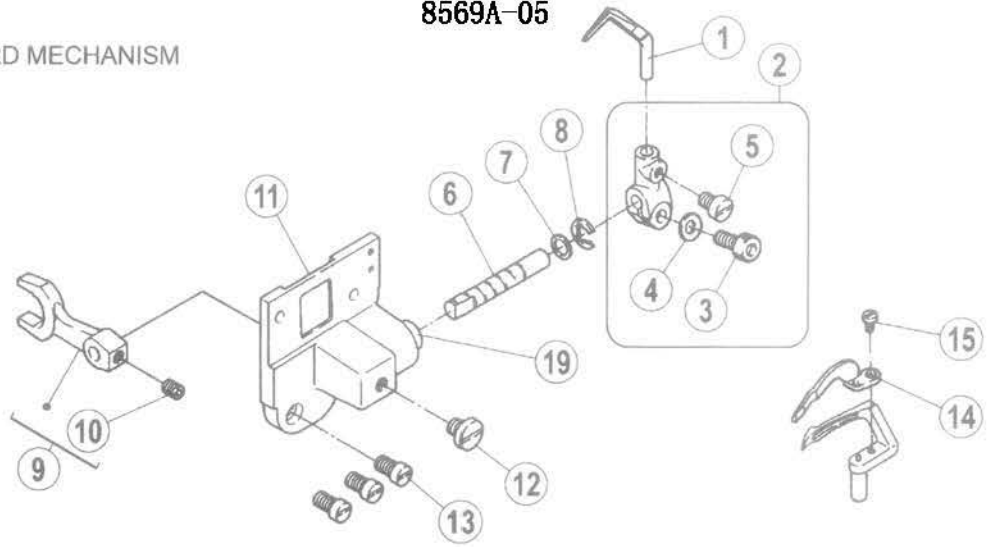

8569A-02D/FT141
8569A-05/FT140

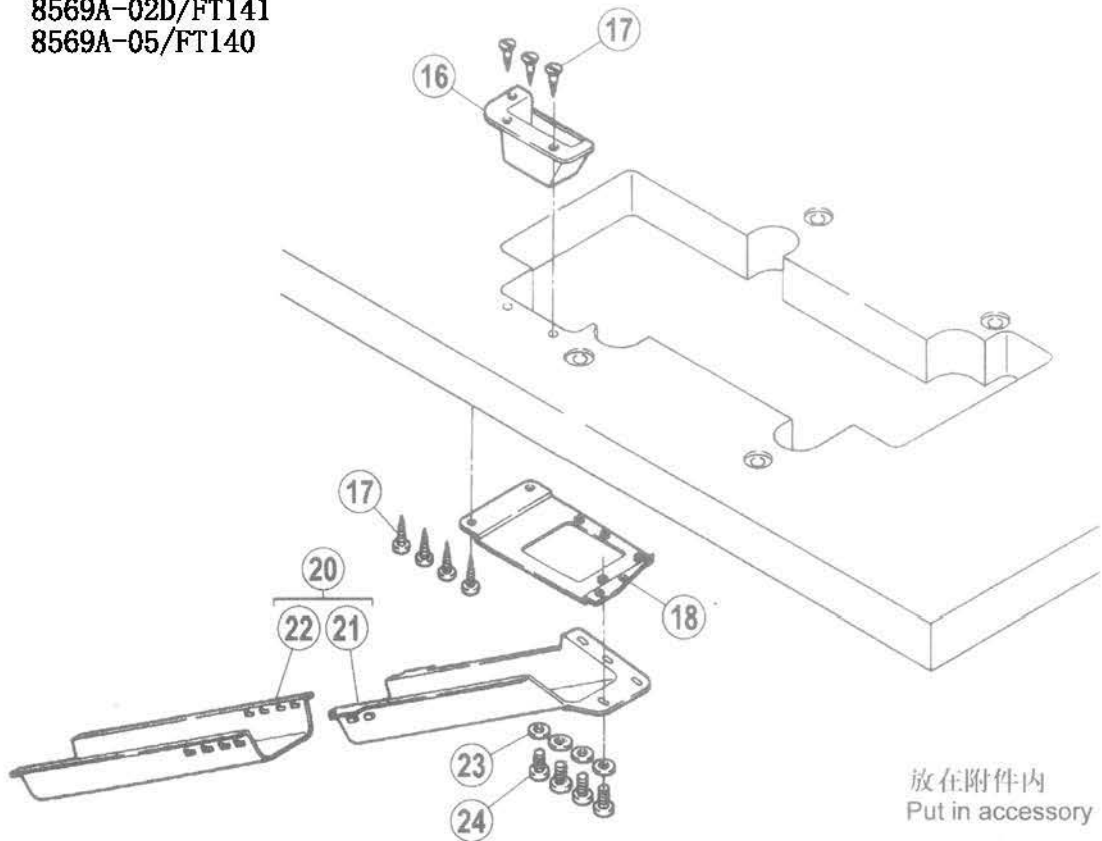

二十六、 02D、05专用部件(02D、05 specific parts)

序号 Ref.No	公司件号 Part No	参考件号 Ref. Part. no	名称	Description	数量 Number
1	30117002	357551B	后护针挡	needle guard(rear)	1
2	30104709	251505-92	护针挡架组件	lever assy	1
3	S05003	4500	螺钉 M5×10	bolt	1
4	W02001	303067	垫圈5	washer	1
5	S01002	7017	螺钉 M4×6.5	screw	1
6	30102037	251503	护针轴	shaft	1
7	W01021		垫片	washer	1
8	H05013	202522	挡圈6	ring	1
9	30106003	251504	叉架	lever	1
10	S10002	4514	螺钉 M5×5	screw	1
11	30101036	251500-91	护针轴座	bracket	1
12	301S11016	7081	螺钉	screw	1
13	S01004	7019	螺钉 M4×7.8	screw	3
14	30117003		前护针挡	needle guard(front)	1
15	S01012		螺钉 M2.5×4	screw	1
16	30111013	306473-UA	挡料斗	waste chute top(C)	1
17	301S30019	4905	木螺钉	screw	7
18	30112048	306474A	托板	bracket	1
19	30103046		套筒	bushing	1
20	3011101400		排料筒座组件	waste chute assy	1
21	30111014	205468-UA	排料筒座	waste chute top(A)	1
22	30111015	205469-UA	排料筒	waste chute top(B)	1
23	30128036		垫片	washer	1
24	S01005	7020	螺钉 M4×10	screw	4

8569A-02D/FT141
8569A-05/FT140

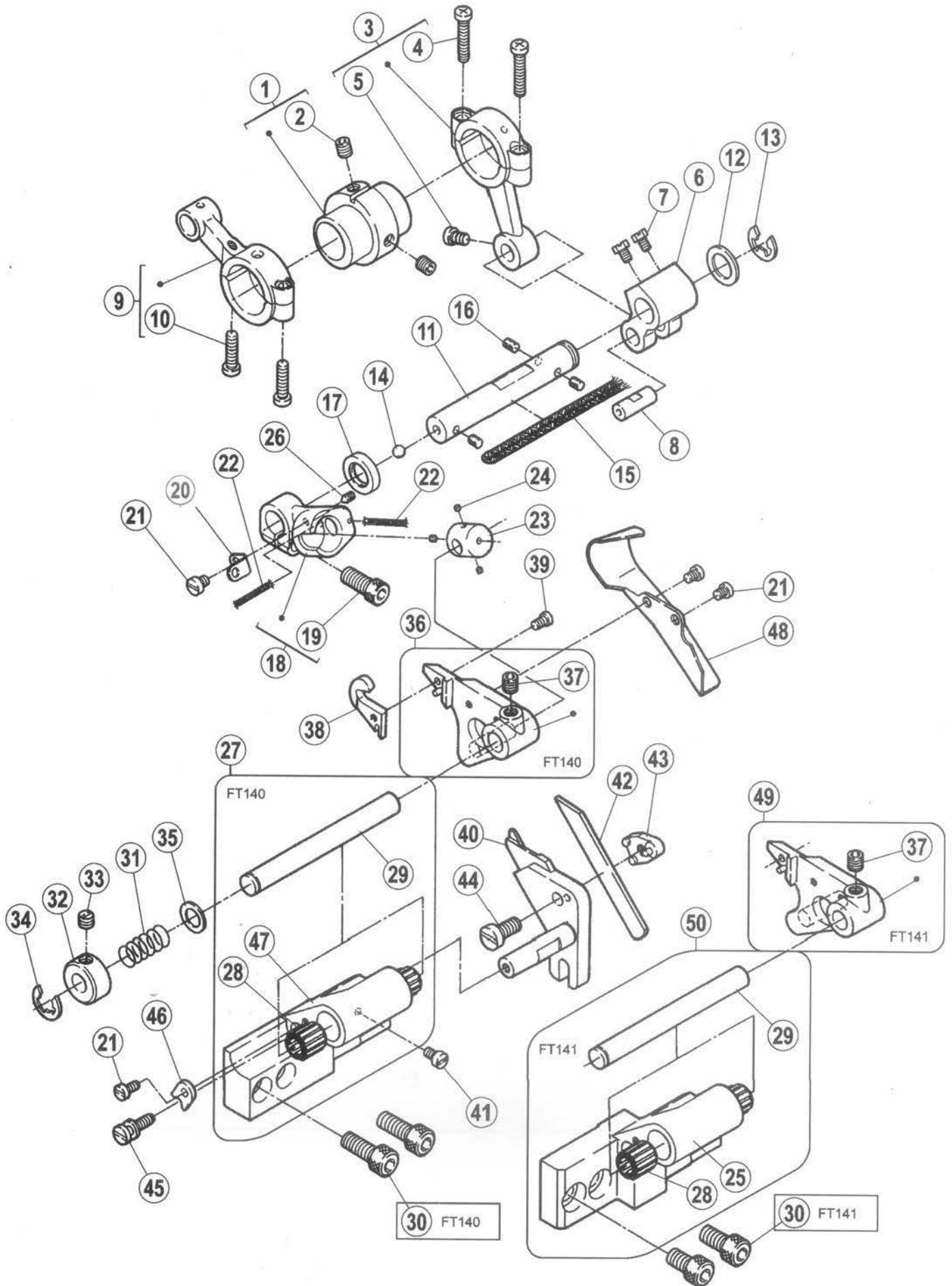

二十七、 02D、05专用部件(02D、05 specific parts)

序号 Ref.No	公司件号 Part No	参考件号 Ref. Part. no	名称	Description	数量 Number
1	30110009	255500	凸轮	eccentric assy	1
2	S10006	4539	螺钉 M5×6	screw	2
3	400062		连杆组件	eccentric assy	1
4	S01008		螺钉 M3.5×13	screw	4
5	S01010		螺钉 M4×8	screw	1
6	30104007		弯针曲柄	crank	1
7	301S12001		螺钉	screw	2
8	30126003		曲柄销	pin	1
9	400063		弯针摆动连杆	connection assy	1
10	S01008		螺钉 M3.5×13	screw	2
11	30102038	255502	曲柄轴	shaft	1
12	30128008	240102	护针轴垫圈	washer	1
13	H05001		垫圈10	ring	1
14	30209009		差动轴滚珠	ball	1
15	20523005		油线	oil wick	1
16	30123001		毛毡	felt	3
17	30122019		油封	oil seal	1
18	30104028	255503	摆轴曲柄	lever assy	1
19	S05004		螺钉 M5×14	screw	1
20	30112049	255504	挡板	latch	1
21	S01006	7009	螺钉 M3×4.5	screw	4
22	30123015		油线	oil wick	2
23	30102039	255505	摆轴	shaft	1
24	30123008		毛毡	felt	3
25	30101040		刀座	bracket assy	1
26	S12002		螺钉 M3×4	screw	1
27	3010104000		刀座组件	bracket assy	1
28	30103085		刀座套筒	needle bearing	2
29	30102040	255508-2	下刀座轴	shaft	1
30	S05019		螺钉 M6×16.3	screw	2
31	30127022	306105	弹簧	spring	1
32	30108006	192024	挡圈	ring	1
33	209S14008	W00024-1	螺钉	screw	1
34	H05013	202522	挡圈	ring	1
35	30128026	207045	垫片	washer	1
36	30101037	255507-91	上刀架	upper knife holder	1
37	S12003	4547	螺钉 M6×0.75×5	screw	1
38	30119001	306394	上刀	upper knife	1
39	301S11017	5109	上刀固定螺钉	screw	1
40	30101039	255509	下刀架	lower knife holder	1
41	301S11025	7036	护针曲柄螺钉	screw	1
42	20619004	204161	下刀	lower knife	1
43	30101038	255510	下刀挡板	lower knife clamp	1
44	S01011	7028	螺钉 M5×10	screw	1
45	301S30021	255513	调节螺钉	screw	1
46	30112051	255511	挡片	guide	1
47	30101040	255506	刀座	bracket assy	1
48	30112050	255515	除削板	chip guard	1
49	30101037		上刀架	upper knife holder	1
50	3010105700		刀座组件	bracket assy	1

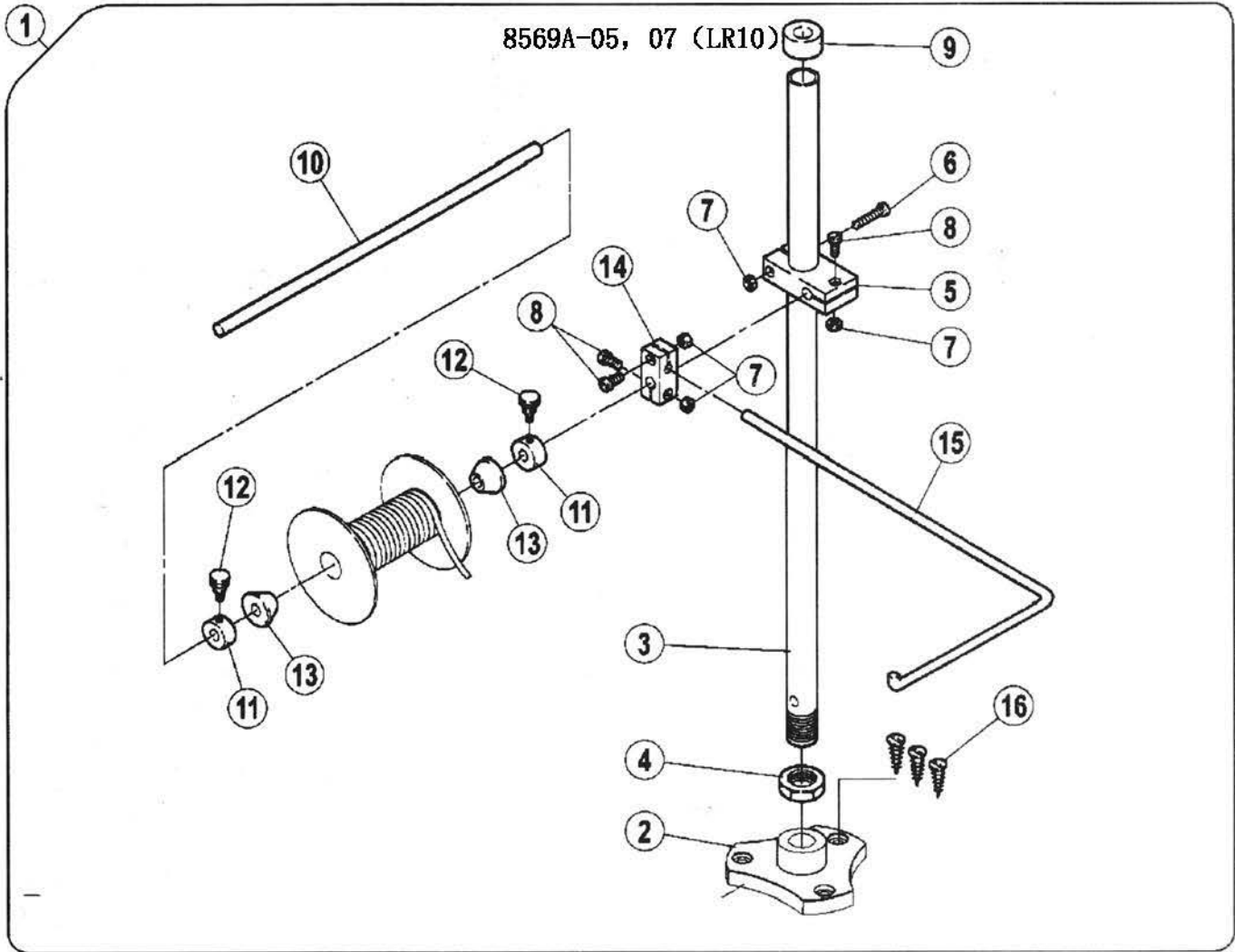

二十八、 05、07专用部件(05、07 specific parts)

序号 Ref.No	公司件号 Part No	参考件号 Ref. Part. no	名称	Description	数量 Number
1	3010204100	306469A9S	带子组件	reel stand assy	1
2	30103047	306468-SA	支柱盘	bracket	1
3	30102042	306466-SA	支柱	rod	1
4	N01026		螺母 M18×1.5	nut	1
5	30111008	383-SA	棒架	bracket	1
6	S04003		螺钉 M4×25	screw	1
7	N01005		螺母 M4	nut	4
8	S04004		螺钉 M4×15	screw	3
9	30122027	386	棒帽	rod cap	1
10	30102043	306464	带架直棒	shaft	1
11	30103048	306463	轴古	collar	2
12	S01068		螺钉 M4×8	screw	2
13	30103064	306462	轴锥架	reel guide	2
14	30111009	233-SA	固定器	bracket	1
15	30113020	306467	带架棒	rod	1
16	301S30022	4913	木螺钉	screw	3

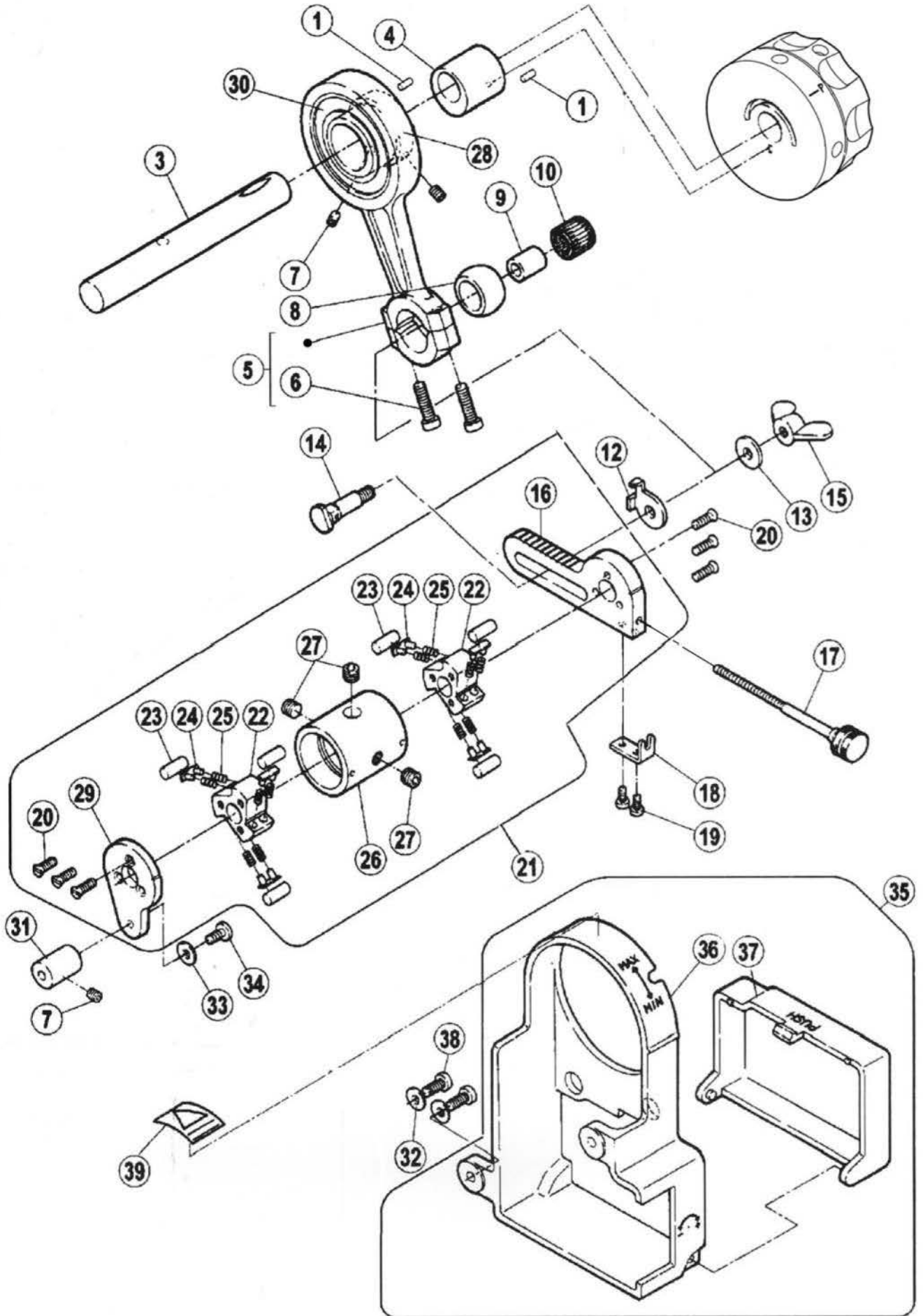

二十九、 05、07专用部件(05、07 specific parts)

序号 Ref.No	公司件号 Part No	参考件号 Ref. Part. no	名称	Description	数量 Number
1	P03008	206781	销 2×6	pin	2
3	30103049	256000	短轴	shaft	1
4	30103050	256043-91	偏心套	eccentric assy	1
5	3010501900	256007	铝连杆组件	connection assy	1
6	S04005		螺钉 M4×15.5	screw	2
7	S10002	4514	螺钉 M5×5	screw	3
8	30103051		球套	ball stud	1
9	30103052	306238	轴承套	bushing	1
10	B07014		轴承 10×13×13	needle bearing	1
12	30112052	256009	调节指针	indicator	1
13	30128027	204023	垫圈	washer	1
14	301S20012	256008	调节螺钉	pin	1
15	301S16009	256048	碟形螺母	nut	1
16	30101041	256010	调节座	crank	1
17	301S30023	256041	长螺钉	screw	1
18	30112053	256042	支座	set plate	1
19	S01006	7009	螺钉 M3×4.5	screw	2
20	301S11019	7083	调节座定位螺钉	screw	6
21	3010104200		三星轮组件	clutch assy	1
22	30101042	256012	轴架	clutch	2
23	30126011	306500	销轴	pin	6
24	30112054	306243	内挡板	guide assy	6
25	30127023	240114A	弹簧	spring	12
26	30103053	256046	轴套	sleeve	1
27	S10029	4547	螺钉 M6×0.75×5	screw	3
28	30103054		轴承套	bushing	1
29	30101043	256011	止动板	stopper plate	1
30	B04006		轴承 (60/28Z)	bearing	1
31	30126012	306568	平行销	pin	1
32	W01001		垫圈4	washer	2
33	W01001		垫圈4	washer	1
34	201S11016		螺钉	screw	1
35	3011101600	250067-UB	护罩组	md cover assy	1
36	30111016		护罩体	md cover	1
37	30111017		护罩板	cover	1
38	S01005	7020	螺钉 M4×10	screw	2
39	30137006		警示牌	sticker	1

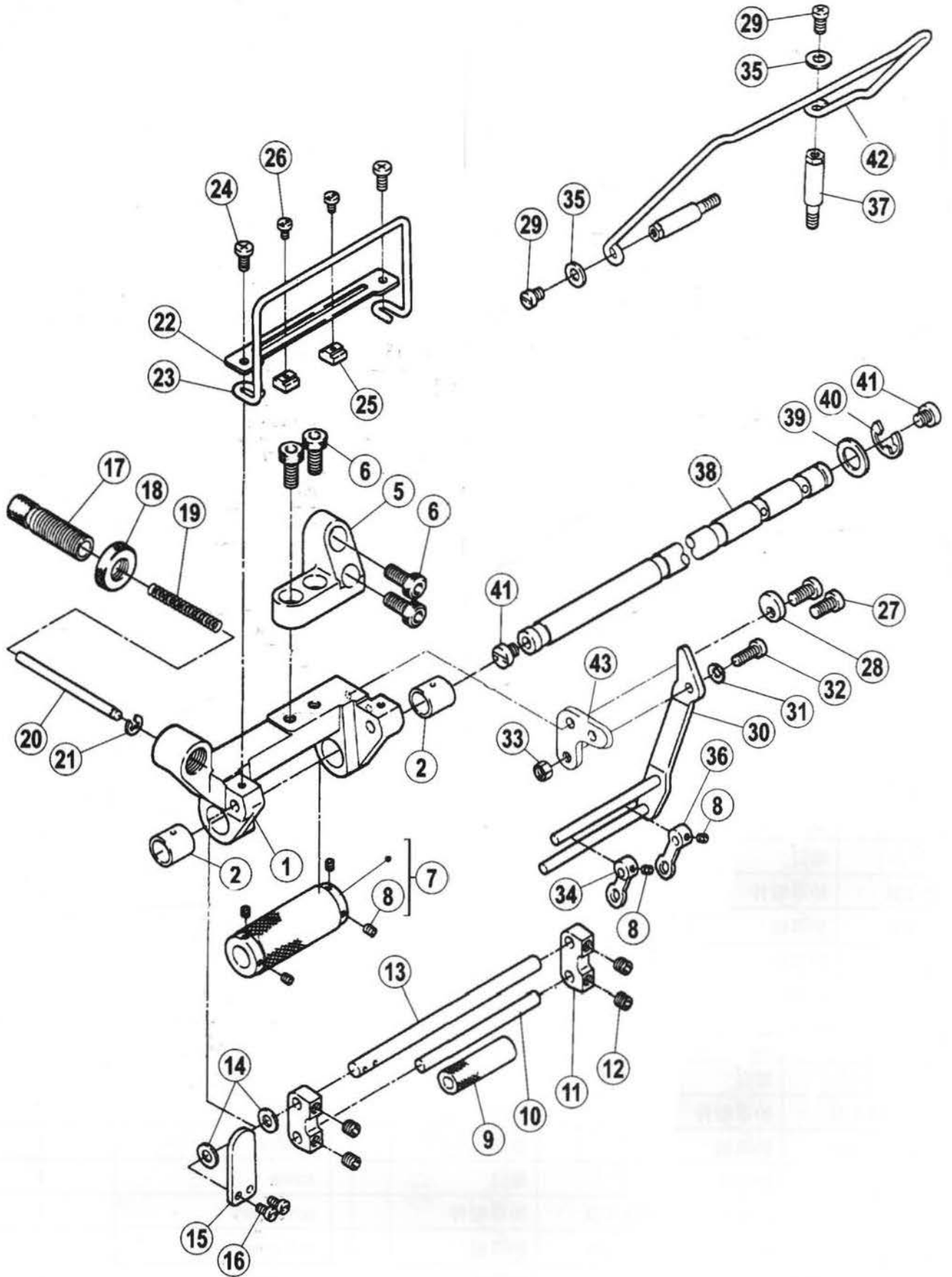

三十、 05、07专用部件(05、07 specific parts)

序号 Ref.No	公司件号 Part No	参考件号 Ref. Part. no	名称	Description	数量 Number
1	300144		压带架座	bracket assy	1
2	30103055		套筒	bushing	2
5	300143		压带架支座	bracket	1
6	S05019		螺钉 M6×16.3	screw	4
7	3010305700		压带轮组件	roller assy	1
8	S10005		螺钉 M3×3	screw	6
9	30103059		皮带轮 II	rooler	1
10	30102045		夹带短轴	shaft	1
11	30109018	255502	夹带轴架	bracket	2
12	S10002	240102	螺钉 M5×5	screw	4
13	30102046		夹带长轴	shaft	1
14	W01003		垫圈6	washer	2
15	30112059		手柄	lever	1
16	S01015		螺钉 M3×5	screw	2
17	301S30027		调节螺钉	screw	1
18	301S16011	255503	调节螺母	nut	1
19	30127024		弹簧	spring	1
20	30126013	255504	销轴	shaft	1
21	H05002	7009	挡圈5	ring	1
22	30112055		压带板	guide	1
23	30113022	255505	压带架	lace guide	1
24	S01002		螺钉 M4×6.5	screw	2
25	301S16010		位置挡块	guide	2
26	301S11018		螺钉	screw	2
27	S01004		螺钉 M4×7.8	screw	2
28	30128028		偏心垫	stopper	1
29	S01004	255508-2	螺钉 M4×7.8	screw	2
30	3011205600		夹带架组件	bracket assy	1
31	30128020	306105	垫片	spring	1
32	S05048	192024	螺钉 M4×10	screw	1
33	N01001	W00024-1	螺母 M4	nut	1
34	30105017	202522	夹带连杆 I	lace guide	1
35	W01004	207045	垫圈5	washer	2
36	30105018	255507-91	夹带连杆 II	lace guide	1
37	301S30025	4547	台螺钉	screw	2
38	30103044	255513	压带轴	shaft	1
39	30128008	255511	摆架轴垫圈	washer	1
40	H05001	255506	挡圈10	ring	1
41	301S11020	255515	压带轴螺钉	screw	2
42	30113021		带子架	lace guide	1
43	30112058		夹带连接板	bracket	1

弯针部件
LOOPER MECHANISM

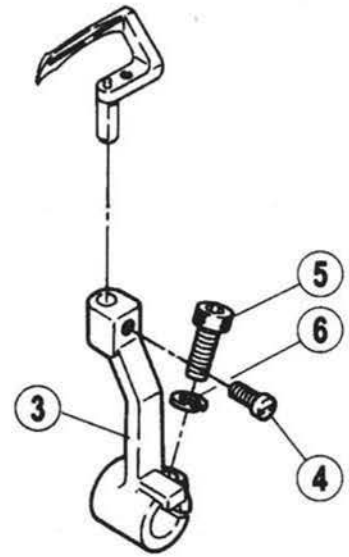
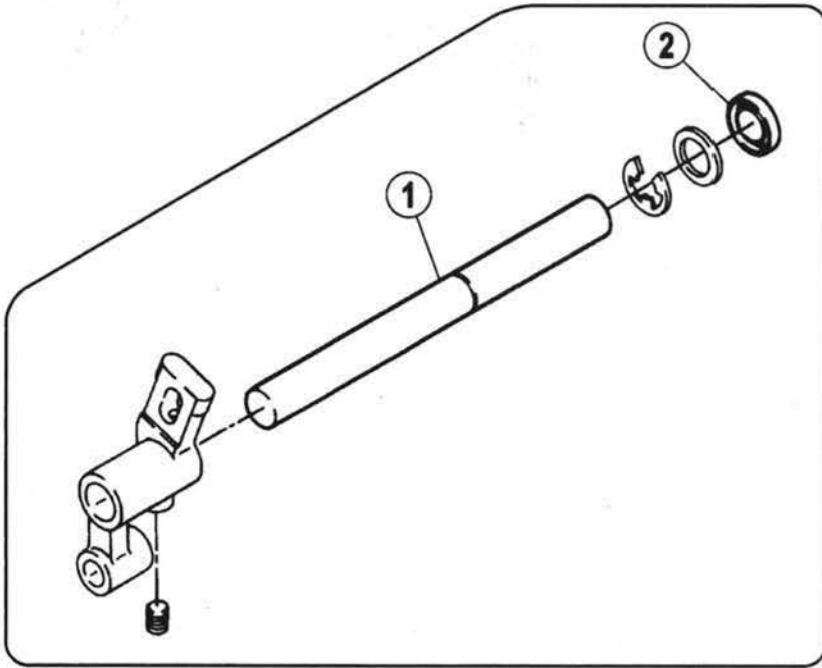

送布部件
FEED MECHANISM

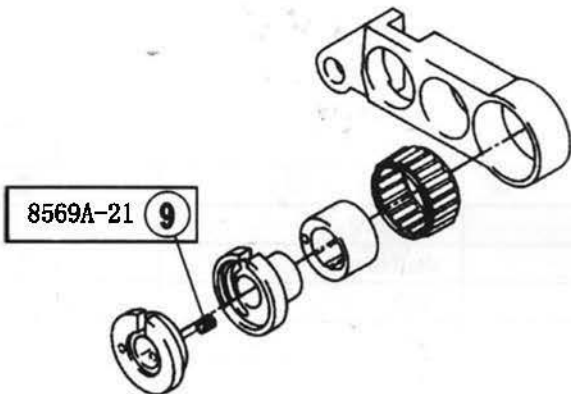
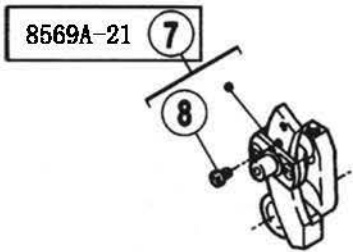

润滑部件
LUBRICATION MECHANISM

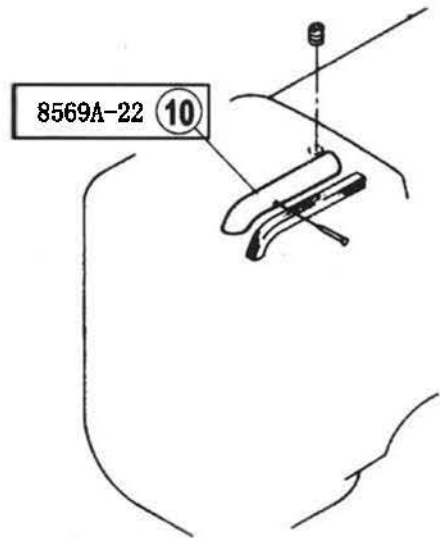

三十一、 21、22专用部件(21、22 specific parts)

序号 Ref.No	公司件号 Part No	参考件号 Ref. Part. no	名称	Description	数量 Number
1	30102051	252004A	摆轴	shaft	1
2	30122008		油封	oil seal	1
3	30104012		弯针架	looper holder assy	1
4	S01004		螺钉 M4×7.8	screw	1
5	S05004		螺钉 M5×14	screw	1
6	W02001		垫圈5	washer	1
7	3010401500		差动调整架组	crank	1
8	S01012		螺钉 M2.5×4	screw	1
9	301S30004	7080	调节器螺钉	screw	1
10	30121012		铜油管	oil pipe	1

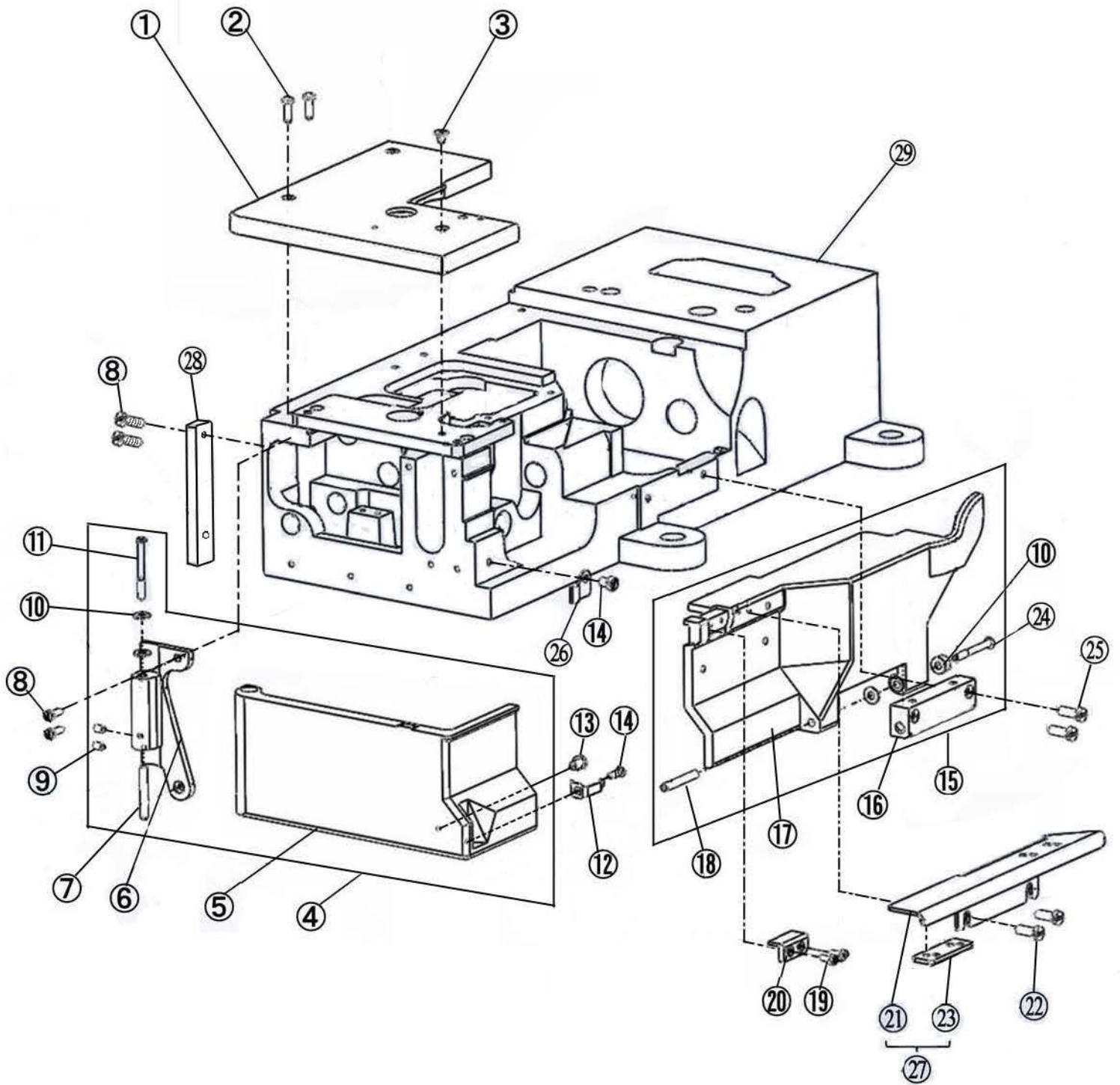

三十二、 8569N专用部件 (8569N specific parts)

序号 Ref.No	公司件号 Part No	参考件号 Ref. Part. no	名称	Description	数量 Number
1	300953		左缝台盖 (喷漆)	bed cover (left)	1
2	S01003	7021	螺钉 M4×12	screw	2
3	S02001	7043	螺钉 M4×6	screw	1
4	300952		侧盖组件 (喷漆)	side coverassy	1
5	30101111		侧盖	side cover	1
6	30101112		侧盖合扇	cover	1
7	301S20005		销螺钉	pin	1
8	S01005	7020	螺钉 M4×10	screw	4
9	S10001		螺钉M3×4	screw	2
10	30128002	201191	弹簧垫圈	spring	5
11	301S20004		侧盖合扇销钉	screw	1
12	30127030		侧前锁紧簧	flat spring	1
13	30122015		前罩防振垫	cushion	1
14	S01002	7017	螺钉 M4×6.5	screw	2
15	300951		加宽前门板组件	front coverasy	1
16	30101063		前罩缝台座	bracket	1
17	30101110		前门板	front cover	1
18	301S20003	250014	前罩缝台座螺钉	pin	1
19	S01006	7009	螺钉 M3×4.5	screw	2
20	30209018		针板座接块	block	1
21	30112097		加宽前门板接板	block	1
22	S01065	7079	螺钉 M5×6	screw	2
23	30112098		加宽前门板接板垫块	baseplate	1
24	301S20002	250013	前罩缝台座螺钉	screw	1
25	S01007	7023	螺钉 M4×13.5	screw	2
26	30112095		侧前锁紧舌	flat spring	1
27	302525		加宽前门板接板组件	front coverasy	1
28	300955		盖板	cover	1
29	302109		机壳	machine frame	1

8569A-23BB (L) /23GB (L)

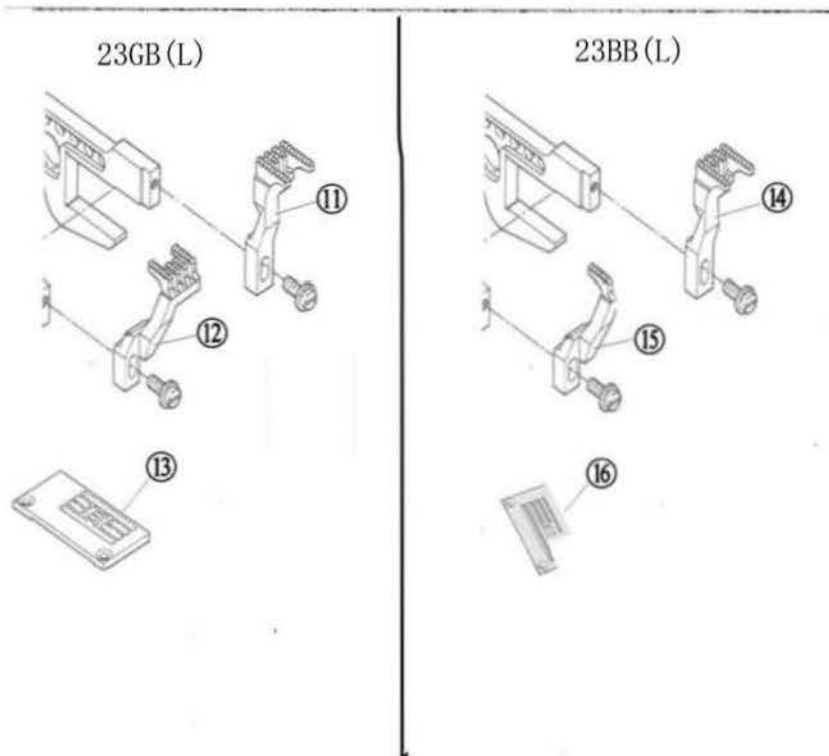
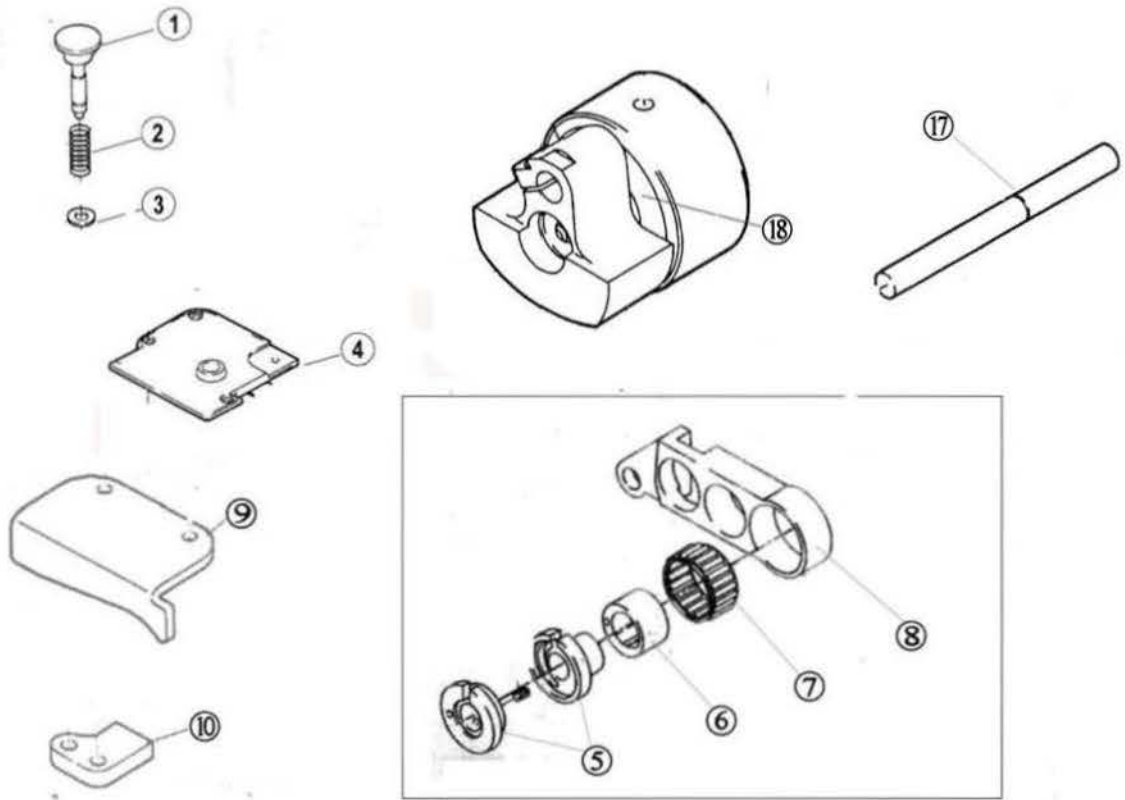

三十三、23专用部件(23 specific parts)

序号 Ref.No	公司件号 Part No	参考件号 Ref. Part. no	名称	Description	数量 Number
1	30126016		针距调节按钮	pin	1
2	30127026		针距调节簧	spring	1
3	12928008		平垫圈	washer	1
4	30101004		下节左盖	cover	1
5	3010308900		调节器套组(大针距)	eccentric retainer	1
	30103088		送布调节器	regulator	1
6	30103087		偏心轴承套(大针距)	eccentric	1
7	B07043		轴承19×23×10	needle bearing	1
8	30104049		差动送布架(大针距)	Link/main feed	1
9	30109025		左挡板	guide (left)	1
10	30109026		挡板	guide (lower)	1
11	30114020		送布牙 (356/364)	main feed dog	1
12	30114021		差动牙 (356/364)	differntial feed dog	1
13	30115043		23GB针板 (356)	needle plate	1
	30115044		23GB针板 (364)	needle plate	1
14	30114024		送布牙 (356/364)	main feed dog	1
15	30114025		差动牙 (356/364)	differntial feed dog	1
16	30115045		2302BB针板 (356)	needle plate	1
	30115046		2302BB针板 (364)	needle plate	1
17	30102051		摆轴	shaft	1
18	400308		针杆曲柄	motion assy	1

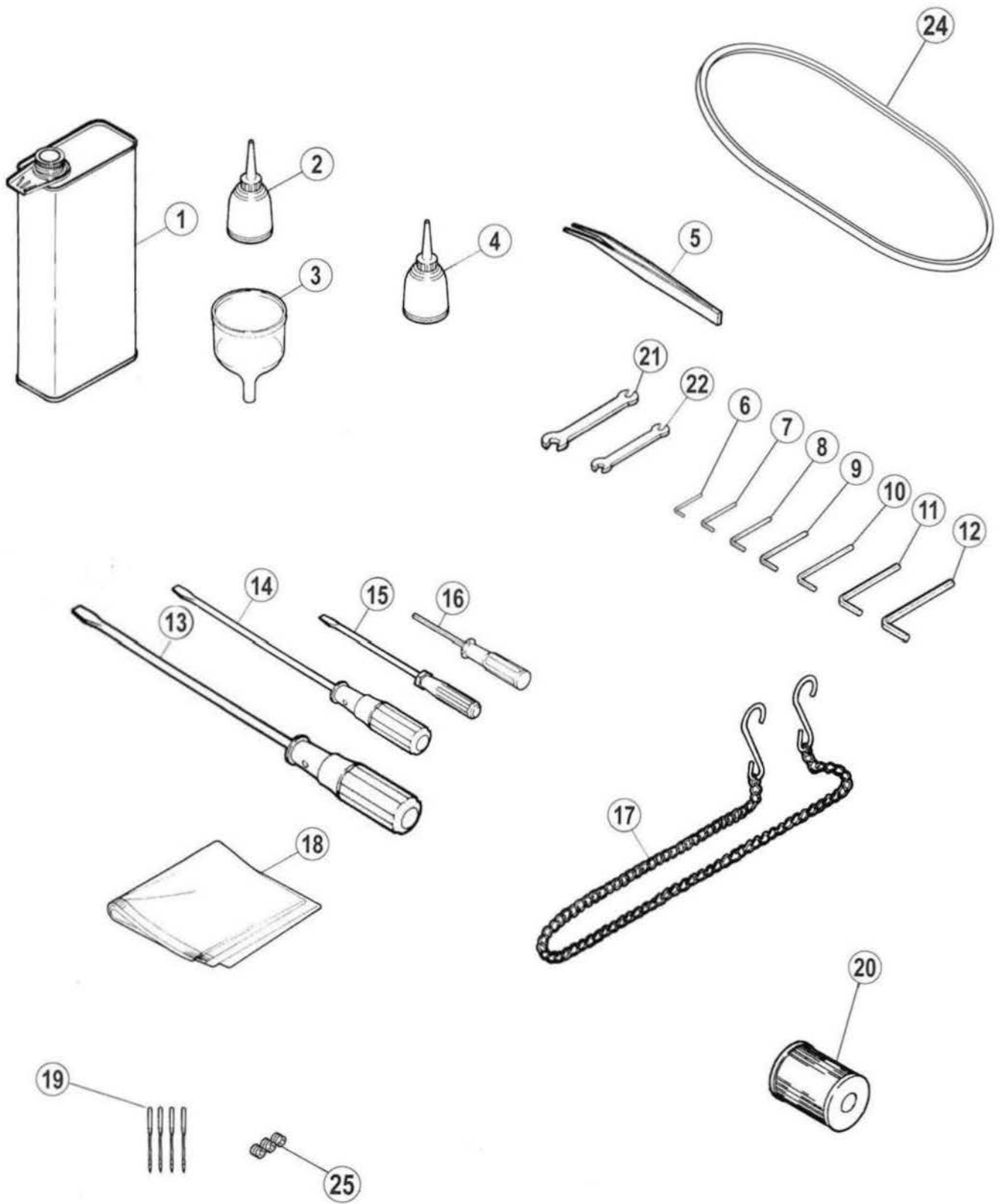

三十四、 附件部件(Accessories assemblies)

序号 Ref.No	公司件号 Part No	参考件号 Ref. Part. no	名称	Description	数量 Number
1	20131037		油壶 (大)	oil container	1
2	20131038		硅油壶	oiler	1
3	20131039		漏斗	oil funnel	1
4	20131038		硅油壶	container silicone	1
5	20131051		镊子	tweezers	1
6	30131007		内六角扳手 (1.5mm)	allen key driver/1.5mm	1
7	20131046		内六角扳手 (2mm)	allen key driver/2mm	1
8	30131010		内六角扳手 (3mm)	allen key driver/3mm	1
9	30131012		内六角扳手 (4mm)	allen key driver/4mm	1
10	20131047		内六角扳手 (5mm)	allen key driver/5mm	1
11	20131056		内六角扳手 (6mm)	allen key driver/6mm	1
12	30131009		内六角扳手 (8mm)	allen key driver/8mm	1
13	10131002		螺丝刀 (大)	screwdriver (large)	1
14	10131003		螺丝刀 (中)	screwdriver (medium)	1
15	10131004		螺丝刀 (小)	screwdriver (small)	1
16	20131044		内六角扳手 (1.5mm直柄)	allen key driver driver/1.5mm	1
17	30131018		链条	chain	1
18	10131005		机头罩	dust cover	1
19	30117001		机针	needle	4
20	20136001		滤油器	filter element	1
21	30131005		扳手 (6mm-7mm)	wrench/(6mm-7mm)	1
22	30131006		扳手 (8mm-10mm)	wrench/(8mm-10mm)	1
24	30135004		皮带	leather belt	1
25	S10005		螺钉 M3×3	screw	3

缝纫组合件

GAUGE PARTS



机型	缝样	针古	针板	主送布牙	差动送布牙	压脚	弯针	护针(前)	护针(后)	喂针	机针
MACHINE TYPE/SPEC.	GAUGE	NEEDLE HOLDER	NEEDLE PLATE	MAINFEED DOG	DIFF.FEED DOG	PRESSER FOOT	LOOP-ER	NEEDLE GUARD		SPREADER	NEEDLE
								FRONT	REAR		
8569A-01GB	356	30134001	30115002	3011400700		3011601300	3011700900	30117002	30117005	30117001(11#)	
8569FA-01GB	364	30134002	30115003			3011601400					
8569A-02BB	356	30134001	30115006	30114006	30114005	30116005	3011700900	30117002	30117005	30117001(11#)	
	364	30134002	30115007			30116006					
8569A-03DB	356	30134001	30115002	3011400700		3011601300	3011700900	30117002	30117005	30117001(11#)	
	364	30134002	30115003			3011601400					
8569A-05CB	356	30134001	30115004	3011400700		30116003	3011700900	30117002	30117005	30117001(11#)	
	364	30134002	30115005			30116004					
8569A-07BB	356	30134001	30115002	3011400700		30116003	3011700900	30117002	30117005	30117001(11#)	
	364	30134002	30115003			30116004					
8569A-08AC	356	30134001	30115004	3011400700		3011601300	3011700900	30117002	30117005	30117001(11#)	
	364	30134002	30115005			3011601400					
8569A-21BB	356	30134001	30115006	30114006	30114005	30116005	3011700900	30117002	30117005	30117011(11#)	
	364	30134002	30115007			30116006					
8569A-23BB	356	30134001	30115045	3011400300		30116027	3011700900	30117002	30117005	30117011(11#)	
8569A-23GB	356	30134001	30115043	30114020	30114021	30116027	3011700900	30117002	30117005	30117011(11#)	
8569A-23BB(L)	256	30134001	30115045	3011400300		30116027	3011700900	30117002	30117005	30117011(14#)	
8569A-23GB(L)	256	30134001	30115043	30114020	30114021	30116027	3011700900	30117002	30117005	30117011(14#)	

产品标准代号: QB/T2044-2010
Standard code of the products: QB/T2044-2010



杰克缝纫机股份有限公司

JACK SEWING MACHINE CO.,LTD.

- 公司地址(Address of Company):
台州市椒江区机场南路15号
No. 15 Rd Airport South, Jiaojiang District Taizhou City, Zhejiang, P.R.C
- 国内销售部(Domestic Trade Department):
电话(TEL): 0086-576-88177788 88177789
传真(FAX): 0086-576-88177758
- 国贸部(International Trade Department):
电话(TEL): 0086-576-88177782 88177774
传真(FAX): 0086-576-88177787
- 零件部(Spare Part Department):
电话(TEL): 0086-576-88177798 88177785
传真(FAX): 0086-576-88177775
- 免费售后服务电话(Aftersale Service TEL): 4008876858
<http://www.chinajack.com>
- 资料如有更改, 恕不另行通知, 以实样为准。
You will be not informed if the file has been revised. Please set sample as standard.
- 2013. 9